

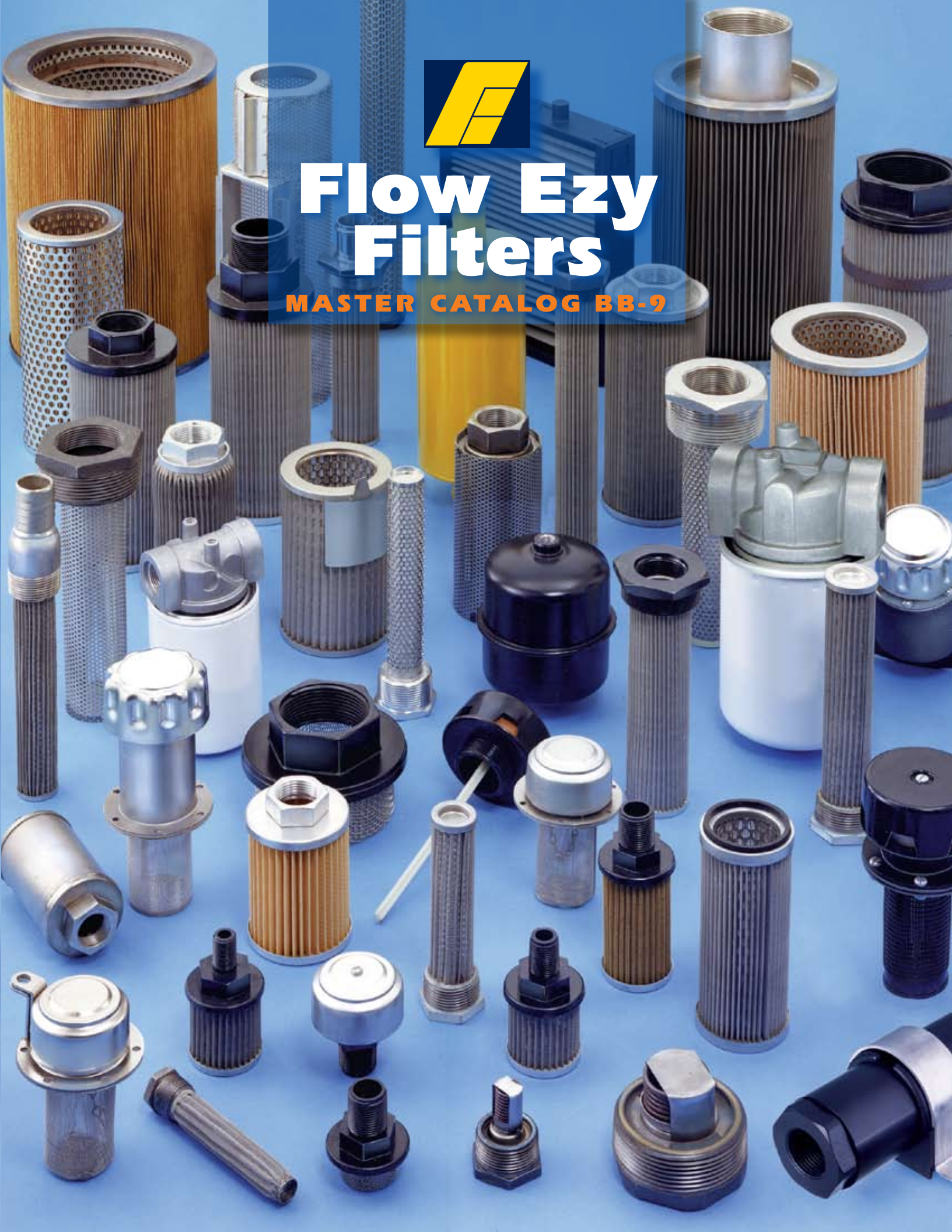

Flow Ezy Filters

MASTER CATALOG BB-9



CUSTOM FILTER MANUFACTURING CAPABILITIES

Did you ever realize the capabilities we have? In addition to our standard product line, we have the capabilities to make most configurations and types of filters. Below you see an assortment of what we have done in past years. If you have an application that requires a custom filter, give us a try.

We most likely will be able to help.

If you need 1, 100, 250, or more,
**FLOW EZY SHOULD BE
YOUR FIRST CONTACT.**



**A COMPLETE LINE
OF HYDRAULIC FILTERS,
STRAINERS AND ACCESSORIES**

We have designed and engineered our complete product line of quality filtration products to meet exacting standards, giving you superior, cost-effective performance. We don't just rest on our reputation of providing only the best products, we strive to keep it.

If you feel the need to contact us for any reason, we encourage you to do so. As our customer, what you have to say is important to us. If you don't find what you're looking for in these pages, give us a call. We're very experienced in producing "specials" that meet our customers' needs. (We may have already built a model similar to your requirements.) So for any reason, please give us a call.

For questions or to place an order, contact us 24 hours a day, 7 days a week by fax or on the internet. We can also be reached by phone 8 AM to 5 PM eastern standard time.

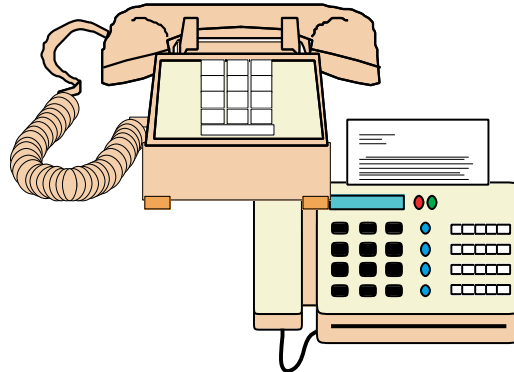

Call us at

734-665-8777 or 800-237-1165

Fax us at

734-665-4432 or 800-252-1730



Or reach us on our website at

www.flowezyfilters.com

Or e-mail us at

flowezy@flowezyfilters.com



FLOW EZY FILTERS

P.O. Box 1749

Ann Arbor, MI 48106

Tel 734-665-8777 or 800-237-1165

Fax 734-665-4332 or 800-252-1730

SALES AND RETURN POLICY

PRICING

All prices are FOB Ann Arbor, MI. All pricing subject to change without notice.

QUOTES

All items not listed in current price lists are subject to quote. All quotes are net cost and are FOB Ann Arbor, MI. Unless otherwise stated all quotes are good for 30 days. Blanket quotes are handled on an individual basis.

PAYMENTS

Standard terms of payment is net 30 days from date of invoice. All past due accounts are subject to 1-1/2% per month on the unpaid balance. Credit hold may take place at 60 days.

GENERAL

All clerical errors are subject to correction.

RUSH ORDERS (UPS RED, BLUE, ORANGE, FEDERAL EXPRESS, ETC.)

Orders must be received no later than 2:00 p.m. Eastern Time in order to be shipped the same day.

SHIPMENTS VIA THE POSTAL SERVICE

There will be a \$25.00 flat additional fee charged for any shipment which requires use of the postal service.

SPECIAL ORDERS

Special orders may require partial or complete prepayment before beginning production.

CANCELLATIONS

Special orders for elements that are built to the customer's specifications cannot be canceled if the order is in production, without cancellation charges.

ADDITION OF ITEMS TO EXISTING ORDERS

Additional items cannot be added to orders that exist but have not shipped.

RETURNS

No goods may be returned without prior authorization and RGA number given by Flow Ezy Filters, Inc.

Shipping discrepancies must be brought to the attention of Flow Ezy Filters within 20 days of receipt of goods.

Special orders built to the customer's specifications cannot be returned.

All authorized returns must be in the original packaging in the original condition and shipped freight prepaid.

Flow Ezy Filters, Inc. reserves the right to issue credit for returned goods upon inspection of the same.

Original purchase order, invoice number, and invoice date of the product being returned must be given to Flow Ezy Filters before a Returned Goods Authorization (RGA) number will be given.

	Page		Page
SUMP STRAINERS			
All-Metal Sump Strainers	4	BACK-PRESSURE INDUCERS	23
All-Steel Sump Strainers	4	JET PNEUMATIC EXHAUST MUFFLERS	23
Nylon Connector Sump Strainers	5	SPIN-ON FILTERS	24
All-Stainless Sump Strainers with Nylon Connector	5	REUSABLE MAGNETS FOR SPIN-ON	25
Crimped-End Sump Strainers	6	REPLACEMENT LUBE FILTERS	25
Disposable Sump Filters	6	300 PSI INLINE FILTERS	26
CASS and MASS Strainers	7	LOW COST IN-LINE FILTERS	
Double Element Sump Filters	8	10-GPM In-Line Filters	27
WASS Mini Suction Strainers	8	7050 Series	27
Nylon Suction Strainers	10	1500 and 3000-psi In-Line Filters	28
Series AN-6235	10	CARTRIDGE FILTER HOUSINGS	29
TEXAS STRAINERS	9	MELTBLOWN CARTRIDGES	30
TANK-MOUNTED STRAINERS	11-13	INDUSTRIAL PROCESS FILTER CATRIDGES	31
FLOW DIFFUSERS	14	A²-SERIES CARTRIDGE FILTER ELEMENTS	32
STRAINER MAGNETS	14	FILTERS	
PIPE-MOUNTED SUCTION SCREENS	15	Y-Filters	33-34
TANK FILLER-BREATHERS		T-Filters	35-36
Top-Mounting Units	16	Texas Filters	37-38
Accessories		Tee-Ezy Filters	39-40
Perforated Inner Guard	16	HIGH- CAPACITY FILTERS/STRAINERS, Models 4-6-8	41-45
Magnet and Post	16	PLEATED BAGS FOR BAG FILTERS	46
Dipstick	20	OIL-ABSORBING INSERT CARTRIDGES	47
Padlock Adapted	16	HYDRAULIC FLANGES	48
Stainless Steel	16	PORTABLE OIL TRANSFER AND FILTER SYSTEM	48
Removable Basket Units	17	HIGH QUALITY WIRE CLOTH	49
All-Nylon Top-Mounting Units	18	REPLACEMENT ELEMENTS	50-82
Units for Pressurized Tanks	18	OTHER FLOW EZY CATALOGS	83
Side-Mounting Units	19		
TANK BREATHERS			
BF Models	20		
NBF Models	20		
Spin-On Filter Elements	21		
Spin-On Air Breather Adapters	21		
Giant Tank Breathers	22		

SUMP STRAINERS – All Metal - All Steel

Sump strainers are used in hydraulic fluids, coolants, lubricants, and many process fluids. Flow Ezy offers them in many different constructions to better match a variety of applications. All have strong perforated metal support tubes under the straining elements. All are available with optional, built-in bypass relief valves to avoid starving the pump should the strainer become dirt-clogged.

ALL-METAL CONSTRUCTION

The traditional all-metal sump strainer has stainless steel pleated elements, in mesh sizes 30 to 200. Continuous epoxy-bonded joints will not leak fluid around the element. They may be cleaned and used indefinitely.

ALL-STEEL CONSTRUCTION

All-steel sump strainers (Style AS) provide greater strength. Otherwise they are the same as the standard unit. (Not a stocked item.)

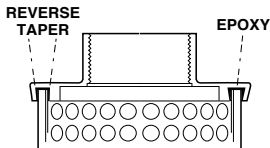

Slot holding epoxy adhesive has a reverse taper on both sides to ensure a positive interlock on all strainers.

HOW TO ORDER

Select the desired specifications from the ordering table and build an ordering code number, as shown in this sample:

AS - **75** - **2-1/2** - **NIPPLE** - **100** - **RV-3**
STYLE - **GPM** - **NPT** - **CONNECTION** - **MESH** - **VALVE**
(spell out NIPPLE if wanted) (omit if not wanted)

STYLE	GPM (Flow Capability)	NPT (Pipe size)	CONNECTION (Nut or Nipple)	MESH (Screen size)	RELIEF VALVE (Optional)
ALL METAL no symbol (aluminum thd. end)	2	1/4*, 1/2*	no symbol (nut)	30	RV-3 (3-psi bypass)
	3	3/8, 1/2*		60	
	5	3/4, 1	100		
	10	3/4, 1		200	
ALL STEEL AS	20	1-1/4	nipple (to get nipple you must specify it)		100
	30	1-1/2			
	50	1-1/2&2			
	75	2-1/2			
	100	3			

*Relief Valve not available
 (Pressure drop through a clean element will not exceed 0.2 psi (0.4-in. Hg) at rated flow of 150 SSU viscosity fluid and 100 mesh.)

NUT STYLE (All-steel construction)

GPM RATING	SCREEN AREA (Sq. Inches)	NPT (Pipe Size)	OVERALL DIMENSIONS	
			Diameter	Length
3	35	3/8, 1/2, 3/4	2-1/8	2-11/16
5	50	3/4, 1, 1-1/4	3-1/16	3-1/16
10	110	3/4, 1, 1-1/4	3-1/16	5-5/16
20	145	3/4, 1, 1-1/4	3-1/16	7-1/8
30	260	1-1/2	4-1/16	9-5/8
50	280	1-1/2 & 2	4-1/16	9-5/8
75	350	2-1/2	5-1/16	12-5/8
100	450	3	5-1/16	12-5/8

NUT STYLE (Metal construction w/cast aluminum top)

GPM RATING	SCREEN AREA (Sq. Inches)	NPT (Pipe Size)	OVERALL DIMENSIONS	
			Diameter	Length
2	25	1/4, 1/2	1-1/4	4
3	35	3/8, 1/2, 3/4	2-1/8	2-11/16
5	50	3/4 & 1	3-9/32	3-1/2
10	110	3/4, 1, 1-1/4	3-9/32	5-3/4
20	145	3/4, 1, 1-1/4	3-9/32	7-3/8
30	260	1-1/2	4-9/32	9-3/4
50	280	1-1/2 & 2	4-9/32	9-3/4
75	350	2-1/2, 3	5-7/16	12-1/2
100	450	2-1/2, 3	5-7/16	12-1/2
150	675	3	5-7/16	17-3/4

NIPPLE STYLE (All-metal construction)

GPM RATING	SCREEN AREA (Sq. Inches)	NPT (Pipe Size)	OVERALL DIMENSIONS	
			Diameter	Length
2	30	1/4, 1/2	1-1/4	4-3/8
3	40	3/8, 3/4	2-1/16	2-7/8
5	62	3/4, 1	3-1/16	3-11/16
10	125	1	3-1/16	6
20	162	1-1/4	3-1/16	7-9/16
30	310	1-1/2	4	9-3/4
50	340	1-1/2, 2	4	9-3/4
75	400	2-1/2, 3	5-1/16	12-5/8
100	500	2-1/2, 3	5-1/16	12-3/4

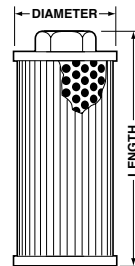

Magnets Available- See Page 14

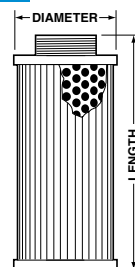

SUMP STRAINERS – Nylon Connector

HOW TO ORDER

Select the desired specifications from the ordering table and build an ordering code number, as shown in this sample:

P - **50** - **2** - **NIPPLE** - **100** - **RV-3**
 STYLE - GPM - NPT - CONNECTION - MESH - VALVE
 (spell out NIPPLE if wanted) (omit if not wanted)

STYLE	GPM (Flow Capacity)	NPT (Pipe size)	CONNECTION (Nut or Nipple)	MESH (Screen size)	VALVE (Optional)
P (std. Nyl-End)	2 3	1/8, 1/4, 3/8, 1/2 1/4	Nut Only	30 60	RV-3 (3-psi bypass)
	3	3/8, 1/2, 3/4	Nut or Nipple (to get nipple you must specify it)		
PASS (S.S. Nyl-End)	5 10 20 30 50	3/4, 1, 1-1/4 3/4, 1, 1-1/4 3/4, 1, 1-1/4 1-1/2 & 2 1-1/2 & 2	Nut no symbol Nipple Style (see chart below)	100	RV-5 (5-psi bypass)
	50	2-1/2	Nipple Only		
	75 100 150	2-1/2 3 3	Nut or Nipple (to get nipple you must specify it)	200	

(Pressure drop through a clean element will not exceed 0.2 psi (0.4-in. Hg) at rated flow of 150 SSU viscosity fluid.)

NYLON CONNECTOR TYPE

“Nyl-End” sump strainers (Style P) are made with the same selection of stainless steel elements as the standard all-metal units. They differ in that the connector end pieces are molded in a single piece of glass-reinforced nylon resin. Pleated stainless elements are epoxy-bonded in place.

They're as serviceable as all-metal units, but they cost 12 to 50 percent less, depending on size.

ALL-STAINLESS CONSTRUCTION

All-stainless-steel sump strainers with nylon connectors (Style PASS) are available in the same wide variety of sizes and element mesh sizes as the standard Nyl-End units. For excellent resistance to oxidation and corrosion. (Not always a stocked item.)

NUT STYLE

GPM RATING	SCREEN AREA (Sq. Inches)	NPT (Pipe Size)	OVERALL DIMENSIONS	
			Diameter	Length
2	30	1/8, 1/4, 3/8, 1/2	1-5/8	4-3/16
3	35	1/4, 3/8, 1/2, 3/4	2-1/4	2-11/16
5	50	3/4, 1, 1-1/4	3-3/16	3-1/2
10	110	3/4, 1, 1-1/4	3-3/16	5-3/4
20	145	3/4, 1, 1-1/4	3-3/16	7-3/8
30	260	1-1/2, 2	4-3/16	9-3/4
50	280	1-1/2, 2	4-3/16	9-3/4
75	350	2-1/2, 3	5-3/16	12-1/2
100	450	2-1/2, 3	5-3/16	12-1/2
150	675	3	5-3/16	17-3/4

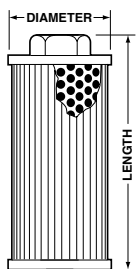

NIPPLE STYLE

GPM RATING	SCREEN AREA (Sq. Inches)	NPT (Pipe Size)	OVERALL DIMENSIONS	
			Diameter	Length
3	35	3/8, 1/2, 3/4	2-1/4	3-3/4
5	50	1	3	3-13/16
10	110	1	3	6-1/16
20	145	1	3	7-11/16
30	260	1-1/2	4-3/16	11-3/8
30	260	2	4-3/16	11-3/8
50	280	1-1/2	4-3/16	11-3/8
50	280	2	4-3/16	11-3/8
50*	280	2-1/2	4-3/16	9-15/16
75	350	2-1/2, 3	5-3/16	13-3/4
100	450	2-1/2, 3	5-3/16	13-3/4
150	675	3	5-3/16	19

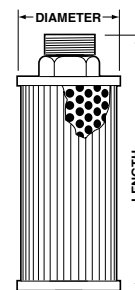

*No hex between nipple and strainer on this part

Magnets Available- See Page 14

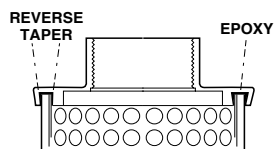

Slot holding epoxy adhesive has a reverse taper on both sides to ensure a positive interlock for strongest possible connection.

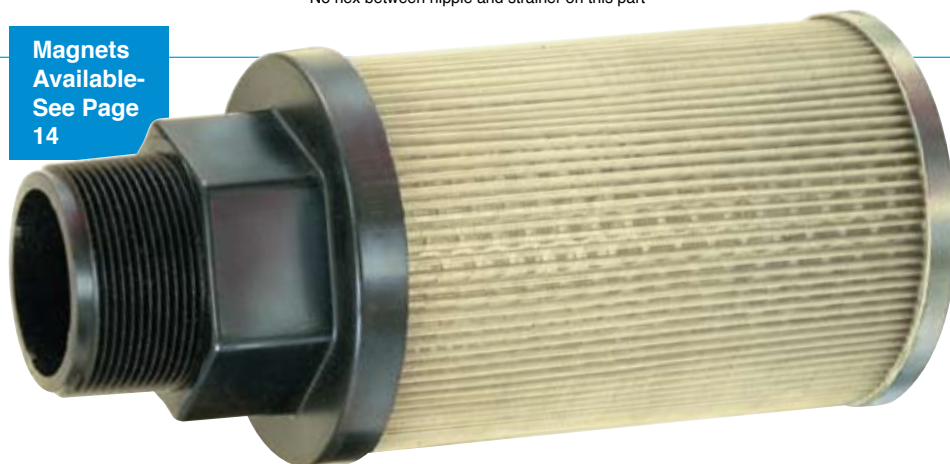

SUMP STRAINERS – Crimped End and Disposable

CRIMPED-END STRAINERS

These are truly all-metal sump strainers, as they do not have any epoxy in their construction. The stainless steel elements are secured through strong mechanical crimping. Good for almost any fluid, especially those that attack epoxy materials. Also for high-temperature applications.

HOW TO ORDER

Select the desired specifications from the ordering table and build an ordering code number, as shown in this example:

C - 50 - 2 - NIPPLE - 60 - RV-3
 STYLE - GPM - NPT - CONNECTION - MESH - VALVE
(spell out NIPPLE if wanted) (omit if not wanted)

STYLE	GPM (Flow Capacity)	NPT (Pipe Size)	CONNECTION (Nut or Nipple)	MESH (Screen Size)	VALVE (Optional)
C (Crimped)	5	3/4	no symbol (nut) To get NIPPLE you must specify it	30	RV-3 (3-psi bypass)
	10	1		60	RV-5 (5-psi bypass)
	20	1-1/4		100	
	30	1-1/2		200	
	50	1-1/2			
	75	2			
	100	2-1/2			

(Pressure drop through a clean element will not exceed 0.2 psi (0.4-in. Hg) at rated flow of 150 SSU viscosity fluid.)

NUT STYLE

GPM RATING	SCREEN AREA (Sq. Inches)	NPT (Pipe Size)	OVERALL DIMENSIONS	
			Diameter	Length
5	50	3/4 & 1	2-7/8	3-1/8
10	110	1	2-7/8	5-3/8
20	145	1-1/4	2-7/8	7-1/8
30	260	1-1/2	3-7/8	9-5/8
50	280	1-1/2 & 2	3-7/8	9-5/8
75	350	2-1/2	5	12-11/16
100	450	3	5	12-11/16

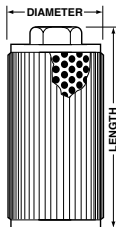

NIPPLE STYLE

GPM RATING	SCREEN AREA (Sq. Inches)	NPT (Pipe Size)	OVERALL DIMENSIONS	
			Diameter	Length
5	50	3/4	2-7/8	3-1/2
10	110	1	2-7/8	5-3/4
20	145	1-1/4	2-7/8	7-5/16
30	260	1-1/2	3-3/4	9-5/8
50	280	1-1/2	3-3/4	9-5/8
75	350	2-1/2	5	12-5/8
100	450	3	5	12-5/8

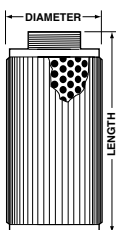

DISPOSABLE FILTERS

These sump filters eliminate the need for cleaning. When fitted with a 10 or 20-micron paper (cellulose) element, they have three times the dirt carrying capacity of a 74 micron metal screen type. When a 40-micron synthetic fiber element is used, the capacity is six times as great as with the metal units.

The pleated paper element is fully supported by a perforated metal tube. These disposable-type sump strainers can also be used as replacement filter elements in many filter housings (that provide a male NPT connection).

HOW TO ORDER

Select the desired specifications from the ordering table and build an ordering code number, as shown in this example:

CS - 3 - 3/4 - 20 - RV-5
 STYLE - GPM - NPT - MICRONS - VALVE
(omit if not wanted)

STYLE	GPM (Flow Capacity)	NPT (Pipe Size)	MICRON (Nominal)	VALVE (Optional)
CS (paper)	1	1/2	10C* 20C* 40A†	RV-3 (3-psi bypass)
	3	3/4		RV-5 (5-psi bypass)
	10	1		

*Cellulose †Synthetic

(Pressure drop through a clean element will not exceed 0.5 psi (1-in. Hg) at rated flow of 150 SSU viscosity fluid.)

GPM RATING	FILTERING AREA (Sq. In.)	MICRONS		OVERALL DIMENSIONS	
		(Nominal)	(Absolute)	Diameter	Length
1	150	10,20,40	40,50,100	3	4-5/8
3	450	10,20,40	40,50,100	4	8-3/8
10	700	40	100	4-1/2	7
10	1400	10,20	40,50	4-1/2	14

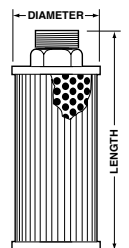

Magnets Available- See Page 14

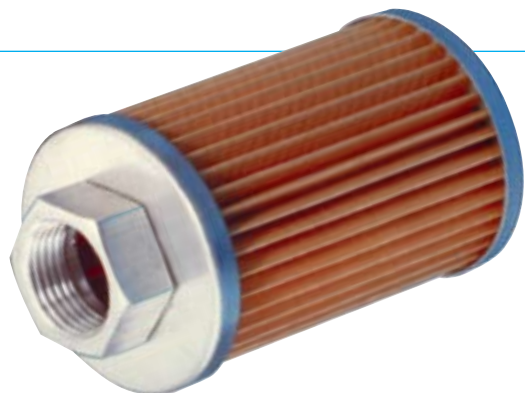

SUMP STRAINERS – All Stainless Steel

HOW TO ORDER

Select the desired specifications from the ordering table and build an ordering code number, as shown in this sample:

CASS - **30** - **1-1/2** - **NIPPLE** - **200** - **RV-3**
STYLE - **GPM** - **NPT** - **CONNECTION** - **MESH** - **VALVE**
 (spell out NIPPLE if wanted) (omit if not wanted)

STYLE	GPM (Flow Capability)	NPT (Pipe size)	CONNECTION (Nut or Nipple)	MESH (Screen size)	VALVE (Optional)
CASS	5	3/4, 1, 1-1/4	no symbol	30	RV-3 (3-psi bypass)
	10	3/4, 1, 1-1/4	(coupling)	60	
	20	3/4, 1, 1-1/4		100	
	30	1-1/2	nipple	200	RV-5 (5-psi bypass)
	50	1-1/2 & 2	(to get nipple you must specify it)		
	75	2-1/2			
100	3				

(Pressure drop through a clean element will not exceed 0.2 psi (0.4-in. Hg) at rated flow of 150 SSU viscosity fluid and 100 mesh.)

CASS SERIES ALL STAINLESS STEEL

This all stainless steel crimped sump strainer comes in mesh sizes 30 to 200. Perforated inner support assures a strong, long-lasting strainer that can be cleaned and used indefinitely.

Magnets Available-
See Page 14



COUPLING STYLE

GPM RATING	SCREEN AREA (Sq. Inches)	NPT (Pipe Size)	OVERALL DIMENSIONS	
			Diameter	Length
5	50	3/4, 1, 1-1/4	2-7/8	3-1/8
10	110	3/4, 1, 1-1/4	2-7/8	5-7/16
20	145	3/4, 1, 1-1/4	2-7/8	7-3/16
30	260	1-1/2	3-3/4	8-13/16
50	280	1-1/2	3-3/4	9-5/8
50	280	2	3-3/4	9-5/8
75	350	2-1/2	5	12-7/16
100	450	3	5	12-1/2

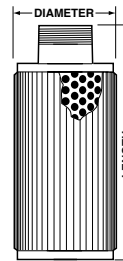
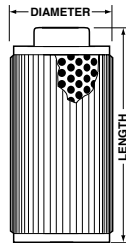

NIPPLE STYLE

GPM RATING	SCREEN AREA (Sq. Inches)	NPT (Pipe Size)	OVERALL DIMENSIONS	
			Diameter	Length
5	50	3/4	2-7/8	3-1/2
10	110	1	2-7/8	5-3/4
20	145	1-1/4	2-7/8	7-5/16
30	260	1-1/2	3-3/4	9-5/8
50	280	1-1/2	3-3/4	9-5/8
50	280	2	3-3/4	9-5/8
75	350	2-1/2	5	12-5/8
100	450	3	5	12-5/8

HOW TO ORDER

Select specifications from the ordering table and build ordering code:

STYLE	GPM (Flow Capability)	NPT (Pipe size)	CONNECTION (Nut or Nipple)	MESH (Screen size)	VALVE (Optional)
MASS	2	3/8, 1/2	no symbol	30	RV-3 (3-psi bypass)
	3	3/8, 1/2, 3/4	(coupling)	60	
	5	3/4, 1, 1-1/4		100	
	10	3/4, 1, 1-1/4	nipple	200	RV-5 (5-psi bypass)
	20	3/4, 1, 1-1/4	(to get nipple you must specify it)		
	30	1-1/2			
50	1-1/2, 2				
75	2-1/2				
100	3				

MASS SERIES ALL STAINLESS STEEL

All stainless steel sump strainers with continuous epoxy-bonded end caps.

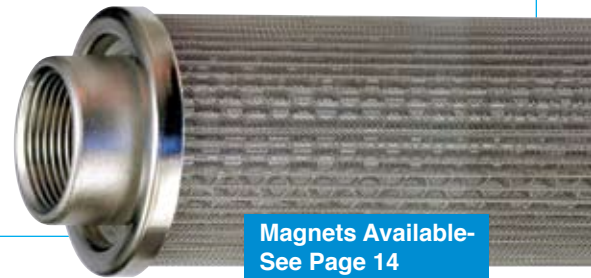

Magnets Available-
See Page 14

COUPLING STYLE

GPM RATING	SCREEN AREA (Sq. Inches)	NPT (Pipe Size)	OVERALL DIMENSIONS	
			Diameter	Length
2	30	3/8, 1/2	1.34	4-1/4
3	35	3/8, 1/2, 3/4	2-1/32	2-11/16
5	50	3/4, 1, 1-1/4	3-1/16	3-1/16
10	110	3/4, 1, 1-1/4	3-1/16	5-9/16
20	145	3/4, 1, 1-1/4	3-1/16	7-1/8
30	260	1-1/2	4-1/16	8-3/4
50	280	1-1/2	4-1/16	9-5/8
50	280	2	4-1/16	9-5/8
75	350	2-1/2	5-1/16	12-5/8
100	450	3	5-1/16	12-5/8

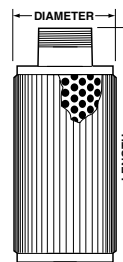
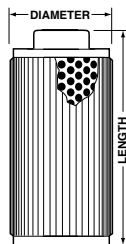

NIPPLE STYLE

GPM RATING	SCREEN AREA (Sq. Inches)	NPT (Pipe Size)	OVERALL DIMENSIONS	
			Diameter	Length
2	30	3/8, 1/2	1.34	4-1/2
3	40	3/8, 1/2, 3/4	2-1/32	2-7/8
5	62	3/4, 1	3-1/16	3-11/16
10	125	3/4, 1, 1-1/4	3-1/16	6
20	162	1-1/4	3-1/16	7-9/16
30	305	1-1/2	4-1/16	9-3/16
50	330	1-1/2	4-1/16	9-13/16
50	330	2	4-1/16	9-13/16
75	390	2-1/2	5-1/16	12-3/4
100	500	3	5-1/16	12-3/4

DOUBLE ELEMENT SUMP FILTERS

SUCTION STRAINERS

REPLACES PRODUCTS FOR:
Michigan Fluid Power (MFP)
Fluid Power Products
Ambac Fluid Power
Fluid Power Systems

These high-quality sump filters meet the special requirements for use with hydraulic oils, coolants, lubricants, and fire-resistant fluids. They have a

unique dual-element construction that provides a much larger filtering area than standard units. This greater filtration capacity makes them ideal for use in the following industries: agriculture, construction, general industrial, material handling, chemical, petroleum, machine tool & metalworking, and processing.

GPM	PORT SIZE NPT	ELEMENT AREA SQ. IN.	HEX A	B	C	D
10	1	130	1-5/8	4-1/16	3-1/8	3
15	1	170	1-5/8	5-1/16	4-1/8	3
20	1-1/4	230	2	6-1/16	5-1/8	3
30	1-1/2	370	2-1/4	6-1/16	5-1/8	4
50	2	450	2-3/4	7-1/16	6-1/8	4
75	2-1/2	540	3-9/16	7-1/16	6-1/4	5
100	3	720	4	8-5/16	7-1/4	5
150	3	920	4	10-5/16	9-1/4	5

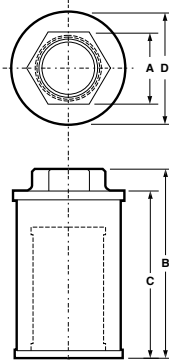

HOW TO ORDER DUAL ELEMENT SUMP FILTERS

Select the desired specifications from the data below and build an ordering code number, as shown in the example:

SR - 75 - 2-1/2 - 100 - RV-3
 STYLE - GPM - NPT - MESH - VALVE
 (omit if not wanted)

STYLE	GPM (Flow Capacity)	NPT (Pipe Size)	MESH (Screen Size)	VALVE (Optional)
SU	10	1	60	RV-3
without bypass	15	1		(3-psi bypass)
20	1-1/4			
SR	30	1-1/2	100	
with bypass	50	2		
75	2-1/2			
100	3			
150	3			

(Pressure drop through a clean element will not exceed 0.2 psi (0.4-in. Hg) at rated flow of 150 SSU viscosity fluid and 100 mesh.)

Magnets are available, order separately.

Magnets Available- See Page 14

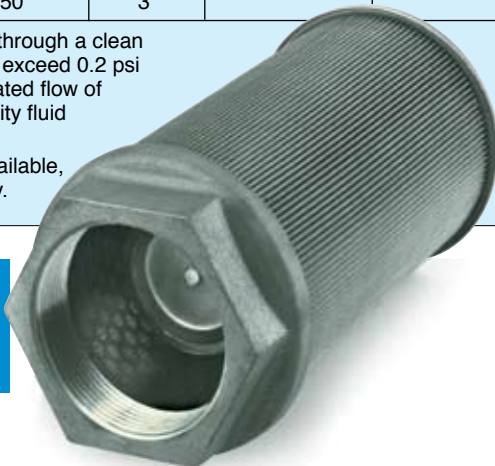

"WASS" style sump strainers are mini-type, welded, and all 304 stainless steel for virtually any fluid compatibility issues. The ends are secured through mechanical crimping. No epoxy is used in the manufacturing of these units. For low-flow applications.

HOW TO ORDER

Select the desired specifications from the ordering table and build an ordering code number, as shown in this example:

WASS - 3 - 1/2 - NIP - 60 - RV-3
 STYLE - GPM - NPT - CONNECTION - MESH - VALVE
 (spell out NIP if wanted) (omit if not wanted)

STYLE	GPM (Flow Capacity)	NPT (Pipe Size)	CONNECTION (Nut or Nipple)	MESH (Screen Size)	VALVE (Optional)
WASS	3	3/8	no symbol (coupling)	30	no symbol (omitted)
		1/2		60	
		3/4*	NIP (nipple)	100	RV-3 (3-psi)
				200**	RV-5 (5-psi)

* 3/4 coupling not available

** 50 x 200 mesh available

NPT	LENGTH	
	COUPLING	NIPPLE
3/8	3-1/16	3-1/2
1/2	3-1/4	3-1/2
3/4	N/A	3-1/2

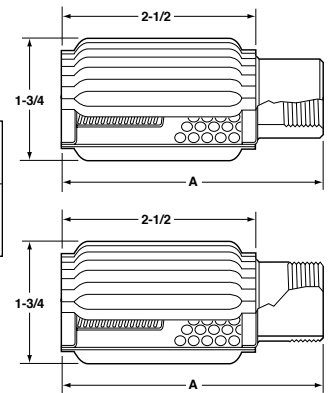

WASS Nipple



WASS Coupling

HOW TO ORDER

Select the desired specifications from the ordering table and build an ordering code number, as shown in this sample:

200 - 2 - N - 5.9 - 30 - RV-3 - ALSS
 GPM - NPT - CONNECTION - DIA. - MESH - VALVE - STYLE

GPM (Flow Capacity)	NPT (Pipe Size)	CONNECTION (Coupling or Nipple)	DIA. (In.)	MESH (Screen Size)	VALVE (Optional)	STYLE
200	2	no symbol (coupling)	5.9	30	RV-3 (3-psi bypass)	ALSS (all stainless steel-omit if not wanted)
	3		8.1	60		
	4		10.2	100		
300	3	N (nipple)	10.2	200	RV-5 (5-psi bypass)	
	4					
	6					
400	4					

*Bypass valve will not handle 100% of rated flow.

These are BIG suction strainers that screw into reservoir suction pipes as large as six inches in diameter, to handle flow rates as high as 600 gpm. Stainless wire screens as fine as 200 mesh and either male (nipple) or female (coupling) connections may be ordered. Each flow size is offered in more than one length/diameter ratio size, to better fit your available space.

Standard Texas strainers are made with mild steel support tubes, end caps, and fittings. They're epoxy bonded for leak-proof service.

DIMENSION TABLE

FLOW RATINGS (based on 150 SUS oil)	200 GPM			300 GPM			400 GPM			600 GPM	
ELEMENT AREA (sq. in. of wire cloth)	1070	965	860	1340	1370	1175	1905	1740	1665	2430	2370
OUTSIDE DIAMETERS (in.)	5.9	8.1	10.2	5.9	8.1	10.2	5.9	8.1	10.2	8.1	10.2
OVERALL LENGTHS (in.)											
With 2" COUPLING	13-5/8	10-3/16	8	Call							
2" NIPPLE	14-3/4	11-5/16	9-1/8	Factory							
3" COUPLING	14-3/4	11-5/16	9-1/8	18-1/16	14-3/4	11-5/16					
3" NIPPLE	15-1/8	11-11/16	9-1/2	18-7/16	15-1/8	11-11/16					
4" COUPLING	15-9/16	11-9/16	9-3/8	18-7/8	15	11-9/16	24-3/4	18-3/16	14-15/16	24-3/16	19-15/16
4" NIPPLE	15-13/16	11-13/16	9-5/8	19-1/8	15-1/4	11-13/16	25	18-7/16	15-3/16	24-7/16	20-3/16
6" COUPLING		12-5/8	9-7/8		16	12-1/16		19-1/4	15-7/16	25-1/4	20-7/16
6" NIPPLE		12-3/4	10		16-1/8	12-3/16		19-3/8	15-9/16	25-3/8	20-9/16

Magnets Available- See Page 14

ALL-STAINLESS CONSTRUCTION

Texas strainers are available constructed entirely of stainless steel, in the same wide variety of sizes and element mesh sizes as the standard units.



NYLON SUCTION STRAINERS

SERIES AN-6235

- **ECONOMICAL**
- **DISPOSABLE**
- **ALL-NYLON CONSTRUCTION**
- **30 MESH-SIZE EQUIVALENT**
- **CORROSIVE RESISTANT**

These all-nylon suction strainers are ideal for use where stainless steel or other metal strainers might corrode or contaminate your fluid. Such applications include water/seawater/de-ionized water, medical/pharmaceutical, general industrial, chemical, and coolant/lubricant. They are available in nut or nipple sizes in flow rates to 3 GPM. The nut style is available in 5 pipe sizes, while the nipple is available in 3. Their unique construction, molded from nylon, offers the equivalent retention of 30 mesh woven wire.

That low-cost construction also makes them economical, easy-to-use, and disposable, saving you time and money.

HOW TO ORDER NYLON SUCTION STRAINERS

Select the desired specifications from the ordering table and build an ordering code number, as shown in this sample:

NYL - 3 - 1/2 - NUT - 30
STYLE - GPM - NPT - CONNECTION - MESH

STYLE	GPM	NPT (Pipe Size)	CONNECTION (Nut or Nipple)	MESH (Screen Size)
NYL	3	1/8	Nut	30
		1/4		
		3/8		
		1/2		
		3/4		
		3/8	Nipple	
	1/2			
	3/4			

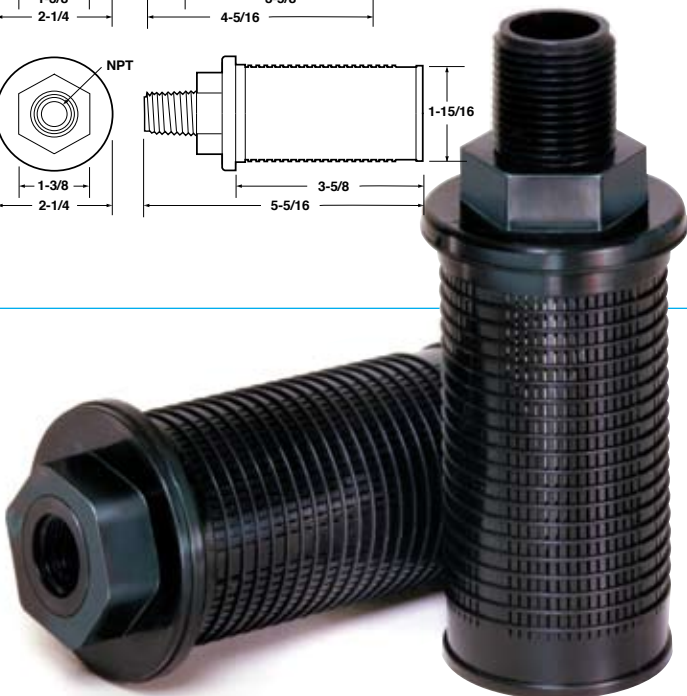
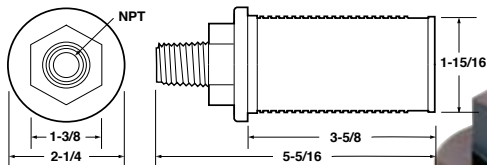
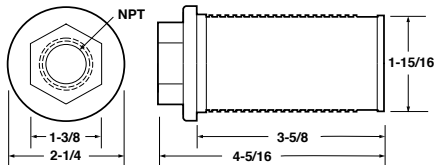

DISPOSABLE AND CLEANABLE LINE TYPE FILTER ELEMENTS

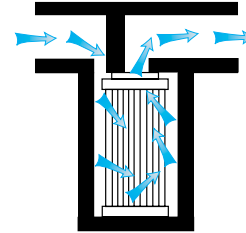

FLOW EZY PART NO.	OLD FLOW EZY PART NO.	A	B	C	O-RING NO.				
AN PART NO. AN-6235-1A									
AN-6235-1A-03G	9133-22	1-7/8	.391	53/64	2-012				
AN-6235-1A-10C	9133-11								
AN-6235-1A-25W	9133-05								
AN-6235-1A-40W	9133-04								
AN-6235-1A-74W	9133-02								
AN-6235-1A-149W	9133-01								
AN-6235-1A-238W	9133								
AN-6235-1A-590W	9133-30M								
AN PART NO. AN-6235-2A									
AN-6235-2A-03G						4-5/8	.641	1-1/8	2-114
10C									
25W									
40W									
74W									
149W									
238W									
590W									
AN PART NO. AN-6235-3A									
AN-6235-3A-03G	6836-03G	3-7/16	.890	1-5/8	2-212				
10C	6836-10C								
10W	6836-10W								
25W	6836-25W								
40W	6836-40W								
74W	6836-74W								
149W	6836-149W								
238W	6836-238W								
590W	6836-590W								
AN PART NO. AN-6235-4A									
AN-6235-4A-03G	6927-03G	4-7/16	1.015	1-3/4	2-214				
10C	6927-10C								
05W	6928-05W								
10W	6928-10W								
25W	6928-25W								
40W	6928-40W								
74W	6928-74W								
149W	6928-149W								
238W	6928-238W								
590W	6928-30 MESH								

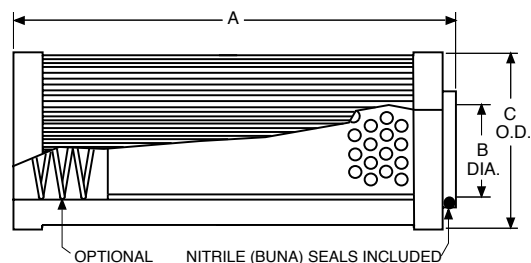

TANK-MOUNTED STRAINERS

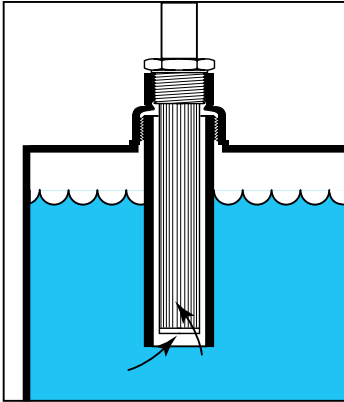

A tank-mounted strainer (either suction or return) can be installed through a tank top by welding a standard bell reducer (coupling) over a hole cut in the top. A standpipe, threaded into the coupling, need be only long enough to stay below the lowest fluid level encountered. The strainer may be removed for servicing without draining the tank.

Flow Ezy tank-mounted strainers and diffusers install through the side wall, or through the tank top and into a standpipe. Either way, they can be removed through the hole in which they are mounted, and access to the tank interior is not necessary. They're made in three styles: for suction straining, return-line straining, or return-line diffusion. Diffusers have no wire cloth elements; their function is to reduce foaming, tank noise, need for baffling plates, and pump cavitation caused by flow disturbance at the pump inlet.

Strainer elements are offered in 30, 60, 100, or 200 mesh size. Bypass relief valves can be supplied, built in.

These products most commonly have a male NPT, to mount to the tank. A male SAE straight-thread is also offered. Several methods of connecting fluid lines exist, the most common being into a female NPT. (A female SAE straight-thread is also offered.) Hose connections, either beaded or barbed, are available too.

There's a wide choice of materials of construction. The standard (and least costly) units have a cast iron bushing, steel support tube, and stainless steel wire cloth element. Also offered are models with forged steel bushings, or an all-welded, all stainless steel unit (no epoxy).

A return-line strainer like that shown (or a suction strainer or flow diffuser) can be mounted through a tank wall.

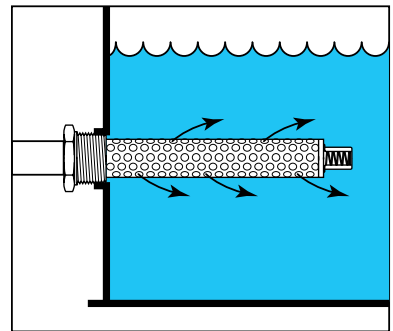

For ordering information, see next pages.

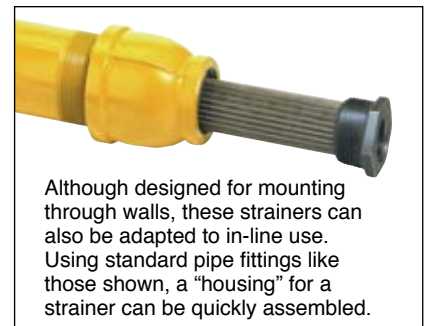

Although designed for mounting through walls, these strainers can also be adapted to in-line use. Using standard pipe fittings like those shown, a "housing" for a strainer can be quickly assembled.

TANK-MOUNTED STRAINERS Dimensions

HOW TO ORDER - Select desired specifications from ordering table and build ordering code number, as shown in sample:

SAMPLE:			S	-	25	-	60	-	RV-5
			STYLE	-	GPM	-	MESH	-	VALVE
STYLE	CONSTRUCTION		GPM (FLOW CAPACITY)			MESH (SCREEN SIZE)			VALVE (OPTIONAL)
SUCTION	S	Iron construction, metal support tube, epoxy bonded	4,5,10,15,25,50,100			30,60,100,200			RV-3 (3-psi bypass)
	SFS	Forged steel bushings, metal support tube, epoxy bonded							
	SASW	All-stainless steel, all welded (no epoxy)							
	ST	Straight-thread steel bushing, metal tube, epoxy bonded	5,10,15,25						RV-5 (5-psi bypass)
RETURN	R	Iron bushings, metal support tube, epoxy bonded	5,10,15,25			30,60,100,200			RV-15 (15-psi bypass)
	RFS	Forged steel bushings, metal support tube, epoxy bonded	19,33,54,94,200,462						
	RASW	All-stainless steel, all welded (no epoxy)							
	RT	Straight-thread steel bushing, metal tube, epoxy bonded	19,33,54,94						
DIFFUSER	D	Iron bushings, perforated metal, epoxy joint	20,34,55,95,209,464			(No wire mesh element)			N/A
	DFS	Forged steel bushings, perforated metal, epoxy joint							
	DASW	All-stainless steel, all welded (no epoxy)							
	DT	Straight-thread steel bushing, perforated metal, epoxy joint	20,34,55,95						

Flow ratings are based on use of schedule 40 pipe.

SUCTION (Style S)

FOR PIPE LINE CONNECTION

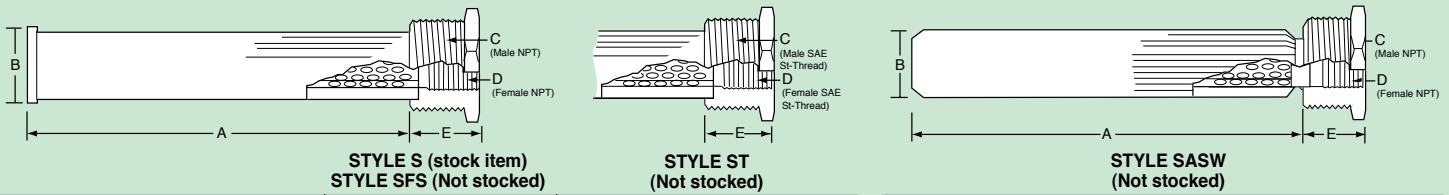

SCREEN AREA (in ²)	GPM	A	B	C (NPT)	D (NPT)	E (Approx.)	C (SAE Thd.)	D (SAE Thd.)	E (Approx.)
34	4	4-1/4	13/16				1-1/16-12	3/4-16	1
5	5	4-1/4	1-1/32	1	1/2	1-1/16	1-5/16-12	3/4-16	1
65	10	6-3/4	1-11/32	1-1/4	3/4	1-1/4	1-5/8-12	1-1/16-12	1
86	15	7-3/16	1-21/32	1-1/2	1	1-5/16	1-7/8-12	1-5/16	1
125	25	8-1/4	2-1/32	2	1-1/4	1-5/16	2-1/2-12	1-5/8-12	1
260	50	8	2-31/32	3	2	1-3/4	3-3/8-12	2-1/2-12	1
315	100	9-5/8	4	4	3	1-3/4			

SCREEN AREA (in ²)	GPM	A	B	C (NPT)	D (NPT)	E (Approx.)
26	5	4-5/8	1-1/8	1	1/2	1-1/16
65	10	7-1/4	1-11/32	1-1/4	3/4	1-3/16
68	15	7-1/2	1-21/32	1-1/2	1	1-1/4
100	25	8-5/8	1-7/8	2	1-1/4	1-1/2
160	50	8-1/4	3-3/16	3	2	1-7/8
275	100	10	4	4	3	2-1/8

RETURN (Style R)

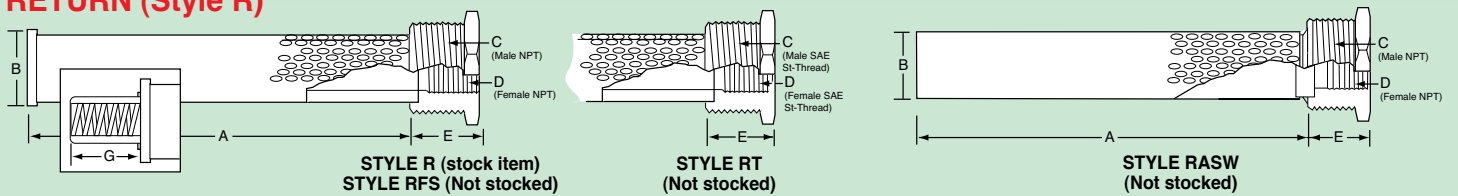

G	SCREEN AREA (in ²)	GPM	A	B	C (NPT)	D (NPT)	E (Approx.)	C (SAE Thd.)	D (SAE Thd.)	E (Approx.)
7/8	34	19	4-1/4	1-1/32	1	1/2	1-1/16	1-5/16-12	3/4-12	1
1	65	33	6-3/4	1-11/32	1-1/4	3/4	1-1/4	1-5/8-12	1-1/16-12	1
1-1/8	86	54	7-3/16	1-21/32	1-1/2	1	1-5/16	1-7/8-12	1-5/16-12	1
1-1/4	125	94	8-1/4	2-1/32	2	1-1/4	1-5/16	2-1/2-12	1-5/8-12	1
1-1/2	260	200	8	2-31/32	3	2	1-3/4	3-3/8-12	2-1/2-12	1
2	315	462	9-5/8	4	4	3	1-3/4			

SCREEN AREA (in ²)	GPM	A	B	C (NPT)	D (NPT)	E (Approx.)
26	19	4-5/8	7/8	1	1/2	1-1/16
65	33	7-1/4	1-1/8	1-1/4	3/4	1-3/16
68	54	7-1/2	1-3/8	1-1/2	1	1-1/4
100	94	8-5/8	1-5/8	2	1-1/4	1-1/2
160	200	8-1/4	2-7/8	3	2	1-7/8
275	462	10	3-5/8	4	3	2-1/8

DIFFUSER (Style D)

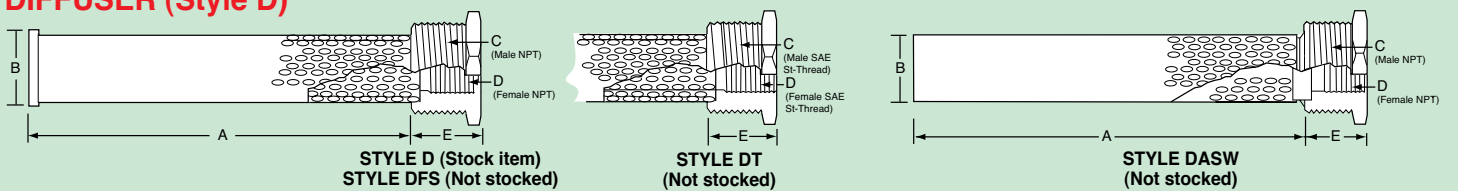

PERF. OPEN AREA (in ²)	GPM	A	B	C (NPT)	D (NPT)	E (Approx.)	C (SAE Thd.)	D (SAE Thd.)	E (Approx.)
3.1	20	4-1/4	7/8	1	1/2	1-1/16	1-5/16-12	3/4-12	1
6.9	34	6-3/4	1-1/8	1-1/4	3/4	1-1/4	1-5/8-12	1-1/16-12	1
8.8	55	7-3/16	1-1/4	1-1/2	1	1-5/16	1-7/8-12	1-5/16-12	1
12.3	95	8-1/4	1-9/16	2	1-1/4	1-5/16	2-1/2-12	1-5/8-12	1
17	209	8	2-1/8	3	2	1-3/4	3-3/8-12	2-1/2-12	1
39	464	9-5/8	4	4	3	1-3/4			

PERF. OPEN AREA (in ²)	GPM	A	B	C (NPT)	D (NPT)	E (Approx.)
3.1	20	4-5/8	7/8	1	1/2	1-1/16
6.9	34	7-1/4	1-1/8	1-1/4	3/4	1-3/16
8.8	55	7-1/2	1-1/4	1-1/2	1	1-1/4
12.3	95	8-5/8	1-9/16	2	1-1/4	1-1/2
21.1	209	8-1/4	2-7/8	3	2	1-7/8
33.2	464	10	3-5/8	4	3	2-1/8

TANK-MOUNTED STRAINERS Dimensions

HOW TO ORDER - Select desired specifications from ordering table and build ordering code number, as shown in sample:

SAMPLE:		SHO	- 25	- 100	- RV-3
		STYLE	GPM	MESH	VALVE
STYLE	CONSTRUCTION		GPM (FLOW CAPACITY)	MESH (SCREEN SIZE)	VALVE (OPTIONAL)
SUCTION	SHO	Steel bushing, metal support tube, epoxy bonded	5,10,15,25,50	30,60,100,200	RV-3 (3-psi bypass) RV-5 (5-psi bypass)
RETURN	RHO	Steel bushing, metal support tube, epoxy bonded	19,33,54,94,200	30,60,100,200	RV-15 (15-psi bypass)
DIFFUSER	DHO	Steel bushing, metal support tube, epoxy bonded	20,34,55,95	(No wire mesh element)	N/A

Flow ratings are based on use of schedule 40 pipe.

FOR HOSE LINE CONNECTION

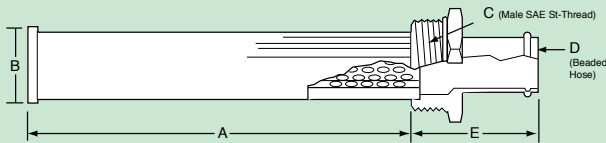

STYLE SHO
(Special, not stocked)

SCREEN AREA (in ²)	GPM	A	B	C (SAE Thd.)	D (Hose ID)	E (Approx.)
34	5	4-1/4	1-1/32	1-5/16-12	1/2	2-1/4
65	10	6-3/4	1-11/32	1-5/8-12	3/4	2-5/16
86	15	7-3/16	1-21/32	1-7/8-12	1	2-5/16
125	25	8-1/4	2-1/32	2-1/2-12	1-1/4	2-1/2
125	30	8-1/4	2-1/32	2-1/2-12	1-1/2	2-1/2
260	50	8	2-31/32	3-3/8-12	2	3

SUCTION

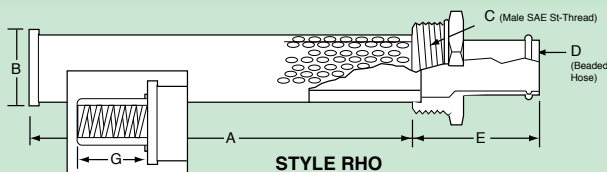
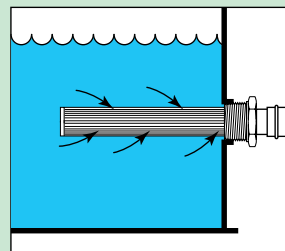

STYLE RHO
(Special, not stocked)

G	SCREEN AREA (in ²)	GPM	A	B	C (SAE Thd.)	D (HOSE ID)	E (APPROX.)
7/8	34	19	4-1/4	1-1/32	1	1/2	2-1/4
1	65	33	6-3/4	1-11/32	1-1/4	3/4	2-5/16
1-1/8	86	54	7-3/16	1-21/32	1-7/8-12	1	2-5/16
1-1/4	125	94	8-1/4	2-1/32	2-1/2-12	1-1/4	2-1/2
1-1/2	260	200	8	2-31/32	3-3/8-12	2	3

RETURN

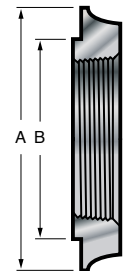
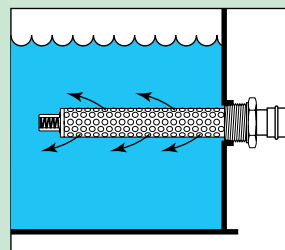

WELD RING - ORDER SEPARATELY

THREAD SIZE	MODEL NUMBER	A	B
1-1/16-12	8632-WR	2-1/4	1-3/8
1-5/16-12	ST-5-WR	2-3/8	1-11/16
1-5/8-12	ST-10-WR	2-11/16	2
1-7/8-12	ST-15-WR	3	2-1/4
2-1/2-12	ST-25-WR	3-1/2	2-5/8
2-1/2-12	ST-30-WR	3-1/2	2-5/8
3-3/8-12	ST-50-WR	4-5/8	3-5/8

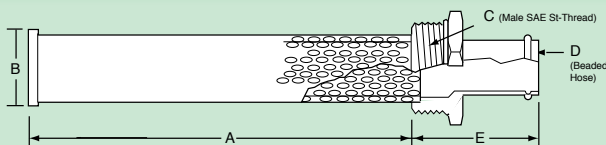

STYLE DHO
(Special, not stocked)

PERFORATION AREA (in ²)	GPM	A	B	C (SAE Thd.)	D (Hose ID)	E (Approx.)
3.1	20	4-1/4	7/8	1-5/16-12	1/2	2-1/4
6.9	34	6-3/4	1-1/8	1-5/8-12	3/4	2-5/16
8.8	55	7-3/16	1-1/4	1-7/8-12	1	2-5/16
12.3	95	8-1/4	1-9/16	2-1/2-12	1-1/4	2-1/2

DIFFUSER

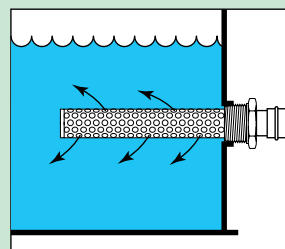

FLOW DIFFUSERS

Flow diffusers are for hydraulic high-speed return lines, to slow down fluids entering the reservoir. They help cure foaming problems and prevent cavitation caused by flow disturbance at the pump inlet. They allow greater freedom in reservoir design, and may even eliminate the need for tank baffling plates. They also reduce reservoir noise.

The unit is of all-steel welded construction, and may be ordered with nut or nipple connector.

HOW TO ORDER

MODEL	Length	Diameter
D-33	3-1/8	3-3/16
D-33 Nipple	4-5/16	
D-54	5-3/8	3-3/16
D-54 Nipple	6-9/16	
D-94	7-3/16	3-3/16
D-94 Nipple	8-1/8	
D-127	8-13/16	4-1/8
D-127 Nipple	9-3/4	
D-210	9-11/16	4-1/8
D-210 Nipple	10-3/8	
D-300	12-11/16	5-1/4
D-300 Nipple	13-1/16	
D-460	12-11/16	5-1/4
D-460 Nipple	13-1/16	
D-700	18-1/4	8-1/4

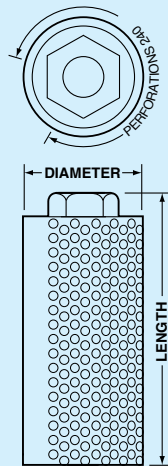

ENGINEERING DATA

Model No.*	Return Flow at 20 ft. Per Sec.** GPM	Connector Size NPT	Total Open Area of Perforations Each .093" Dia.	Ratio of Area Perforations: PIPE
D-33	33	3/4	5 Sq. In.	8.8:1
D-54	54	1	11 Sq. In.	13:1
D-94	94	1-1/4	16 Sq. In.	11:1
D-127	127	1-1/2	26 Sq. In.	13:1
D-210	210	2	28 Sq. In.	8.3:1
D-300	300	2-1/2	48 Sq. In.	10:1
D-460	460	3	48 Sq. In.	6.5:1
D-700	700	4 & 6	SPECIAL ORDER ONLY	

*When ordering a NIPPLE connection, add word NIPPLE to model number
 **Returning fluid speed, based on use of Schedule 40 pipe.



STRAINER MAGNETS

Flex-Wrap Magnets make sump strainers work better. These flexible magnets wrap around strainer elements to help catch tiny iron particles which might otherwise get through the mesh, thus improving strainer performance. They are easy to install, easy to remove for cleaning, and easy to clean (just wipe with a cloth). They don't block the pleats of the strainer; they just touch the tops.

Flex-Wrap Magnets are available in sizes for use on strainer elements with:

- 2-in. OD (3-gpm strainer),
- 3-in. OD (5-, 10- & 20-gpm strainers),
- 4-in. OD (30- & 50-gpm strainers),
- 5-in. OD (75- & 100-gpm strainers),
- and 6, 8 and 10-in. OD (for Texas strainers).

Many other sizes available. Call factory.

RECOMMENDED USAGE ON FLOW EZY STRAINERS IS (Order by OD):

For Strainer Element		Recommended Number of Magnets
OD (in.)	GPM	
2	3	1
3	5,10,20	2
4	30,50	2
5	75,100	4
6,8,10	Texas Strainer	4



PIPE-MOUNTED SUCTION SCREENS

MESH SIZE TABLE

U.S. MESH	INCHES	MICRONS
4	.187	4760
6	.132	3360
8	.0937	2380
10	.0787	2000
20	.0331	841
30	.0232	595
40	.0165	420
60/30*	.0098	250
100/30*	.0059	149
200/30*	.0029	74

*The "30" stands for the mesh size of the support screen.

Suction screens can be used for straining oil, chemical liquids, and water. They will not rust. They're made of tough glass-filled nylon resins with stainless steel wire cloth elements. With male or female NPT connectors, to thread into or onto pipe. There are ten wire mesh sizes to choose from. The finer 60-, 100-, and 200-mesh size screens are backed up with a heavier 30-mesh inner support.

HOW TO ORDER

NUT STYLE STRAINERS

PART NO.	NPT (Pipe Size)	SCREEN AREA (Sq. in.)	DIMENSIONS				
			A	B	C	HEX	
F-01	1/8	3.1	1-1/2	1-5/8	1	1-3/8	
F-02	1/4						
F-03	3/8						
F-04	1/2						
F-1	1/8	6.5	1-1/2	2-1/4	1-1/2	1-3/8	
F-2	1/4						
F-3	3/8						
F-4	1/2						
F-5	3/4						
F-6	3/4	14.75	2-1/8	3-3/16	2-1/2	1-3/8	
F-8	1						1-5/8
F-10	1-1/4						2
F-12	1-1/2	27.5	2-5/8	4-3/16	3-1/2	2-1/4	
F-16	2						2-3/4
F-20	2-1/2	46	3-1/2	5-3/16	4-1/2	3-1/4	
F-24	3						4

Choose a part number from the nut or nipple table and add the mesh size desired from the mesh size table located above.

Example:

A 2-in. nut-style strainer is part number F-16, and ordering it with a 20-mesh wire screen would add "20" to the part number, making it F-16-20.

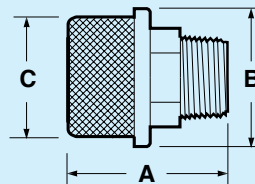
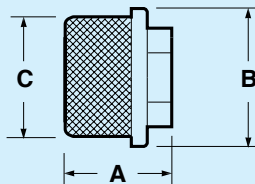

NIPPLE STYLE STRAINERS

PART NO.	NPT (Pipe Size)	SCREEN AREA	DIMENSIONS					
			A	B	C			
M3	3/8	6.5	2-1/2	2-1/4	1-1/2			
M4	1/2							
M6	3/4							
M8	1	11.2	2-1/2	3	2-1/8			
M16	2					4-1/4	4-3/16	3-1/2
M20	2-1/2					2-7/8*		
M24	3					4-5/8	5-3/16	4-1/2

* No hex between nipple and strainer on this part

ALL STAINLESS STEEL SUCTION SCREEN

Perfect for straining paint, petroleum based fluids, chemical liquids, or water. Not affected by temperature, will not strip, pull loose, or crack. 2-1/4" OD x 1-1/2" tall

HOW TO ORDER:

Example: **F6 - 30/8 - SS**

Model No.

1/2" NPT = F4

3/4" NPT = F6

1" NPT = F8

Mesh Size:

16 over 8 mesh = 16/8

30 over 8 mesh = 30/8

60 over 8 mesh = 60/8

Stainless Steel = SS

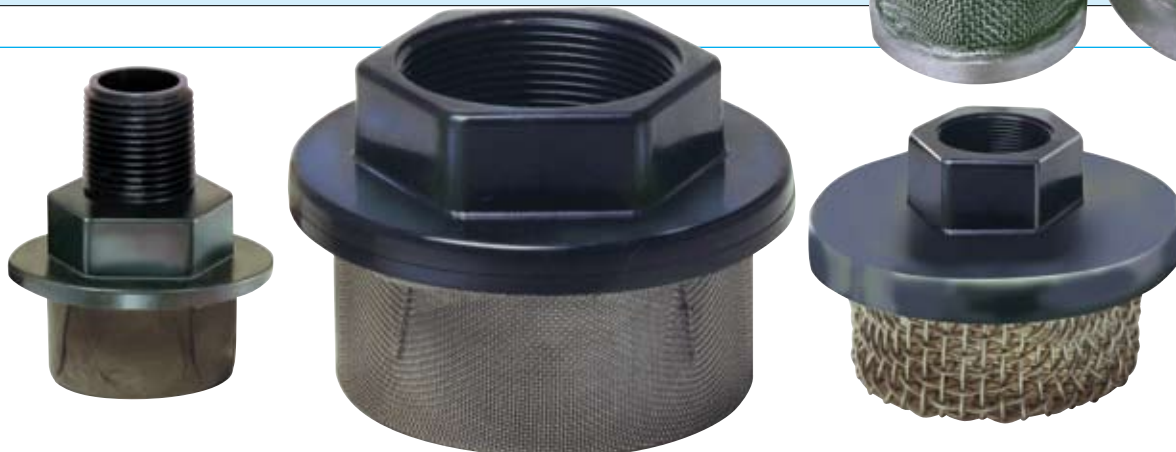
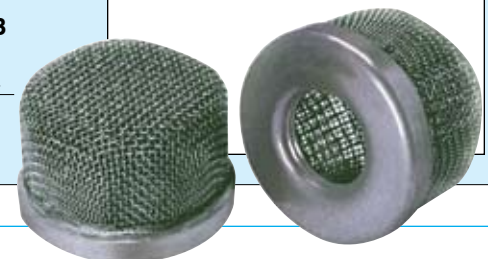

TANK FILLER-BREATHERS

These provide filler ports for hydraulic power unit tanks or other liquid reservoirs. Liquids are strained as they are added to the tank and it lets the tank breathe filtered air.

The 30-mesh filler screen removes dirt and debris from liquids as they enter the systems. The breather cap filters the air, trapping airborne dirt down to 40- or 10-micron levels. It permits air passage at up to 25 scfm. Mounting hardware, gaskets, and templates are supplied.

ACCESSORIES

PERFORATED INNER GUARD:

Protects strainer basket against puncture. Four sizes (3", 6", 8" and 13") to match basket depths.

MAGNET AND POST: Attaches to bottom of basket, removes tiny iron particles which can sift through the screen. Impervious to hydraulic fluid. Three sizes (3", 6", and 8").

DIPSTICK: Attaches to cap. Can be marked to order: FULL, ADD, etc. Supplied in lengths (3", 6", 8" and 13"). Eliminates safety chain. If chain is wanted, it must be ordered.

The standard filler cap can be ordered with these modifications:

Padlock adapted. To help prevent tampering, the cap and mount can have welded lugs to allow use of a padlock. Specify "padlock adapted".

Stainless steel. Stainless caps and all-stainless units are available. Specify "stainless cap" or "all stainless" (AB only).

STEEL TOP-MOUNTING UNITS

If funnels are used for filling, it is recommended that the screen basket be ordered at least 6-inches deep, to prevent accidental puncturing. Perforated metal inner guards may be ordered also, to prevent damage to the screen.

To help prevent tank-top dirt from plugging up the air filter you can order a 'high-neck' model. It puts the air filter 3 inches above the tank top. A 'grip' cap is another option: it is a larger, nickel-plated filler cup with curved indentations to provide a better gripping surface. Ideal for outdoor or oily environments.

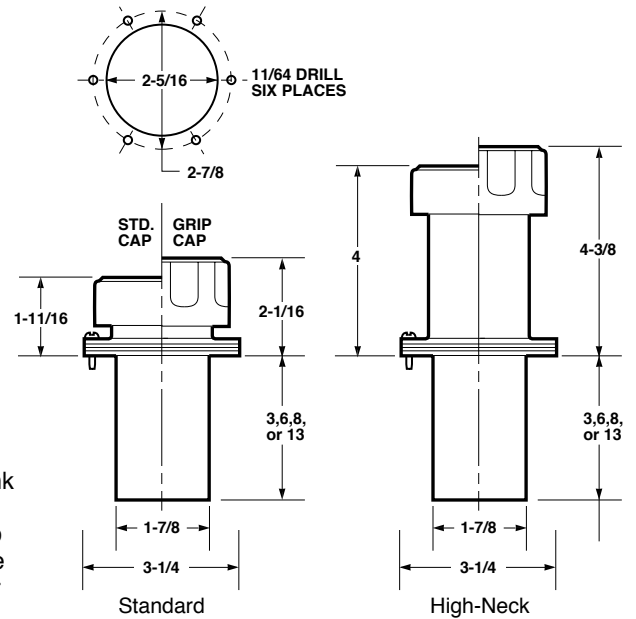

HOW TO ORDER TOP-MOUNTED UNITS

Select the desired specifications from the ordering table and build an ordering code number, as shown in this example:

AB - 1000 - 6 - HN - G - DS-6 - M8 - LL - BPC
 CAP ELEMENT BASKET NECK GUARD DIP Magnet Lockable
 (omit if not wanted)

CAP Type	ELEMENT (Micron)	BASKET Depth (in.)	NECK Height	INNER GUARD	DIP STICK****	MAGNET and POST	Lock Lugs	BLACK POWDER COATED
AB* (Std.)	1000 (40)	3 6 8	No Symbol (Std.)	No symbol (no guard)	No Symbol (No stick)	No Symbol (no magnet)	LL	BPC
ABG** (Grip type)	1010 (10)	13	HN*** (High neck)	G (guard)	DS-3*** (3-in.) DS-6*** (6-in.) DS-8*** (8-in.) DS-13*** (13-in.)	M3 (3-in. post) M6 (6-in. post) M8 (8-in. post)		ABG ABGP (only)
ABNV (Non-vented)								

*Stainless steel available on AB only. **ABG comes nickel plated or black powder coated.

No chain unless specifically ordered. *Dip stick markings available (minimum order and extra charge).

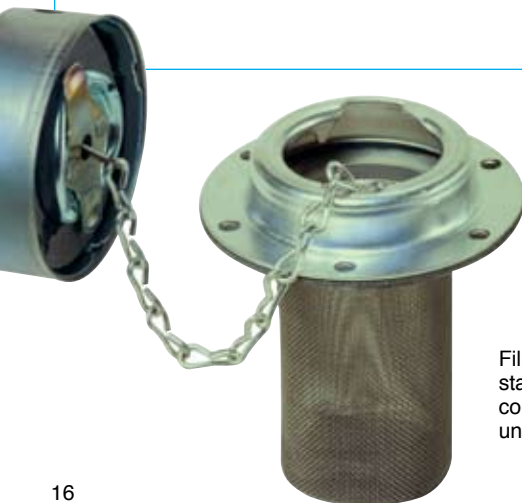

Filler-breathers with standard neck heights come with safety chains unless ordered without.



Basket with inner guard and magnet.

TANK FILLER-BREATHERS

REMOVABLE BASKET UNITS

The strainer baskets in these units pull out creating an easy point of entry into a hydraulic or lube oil reservoir for a suction hose. Allows easy removal of fluid. They are available with the same choice in accessories as the standard top-mounting units have. It's also easier to clean the basket of any dirt accumulation.

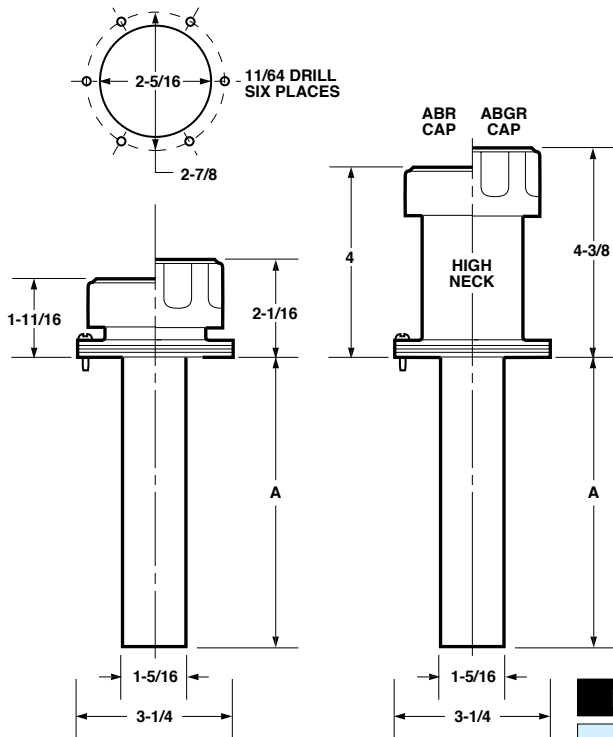

HOW TO ORDER REMOVABLE BASKET UNITS

Select the desired specifications from the ordering table and build an ordering code number, as shown in this example:

ABR - 1000 - 6 - HN - DS-6 - LL - BPC
 CAP ELEMENT BASKET NECK DIP Lockable Powder Coated
 (R = Removable) (omit if not wanted)

CAP Type	ELEMENT (Micron)	BASKET(A) Depth (in.)	NECK Height	DIP Stick***	Lock Lugs	Black Powder Coated
ABR* (Std.)	1000 (40)	3 6 8	No Symbol (Std.)	No Symbol (No stick)	LL	BPC (ABG style only)
ABGR (Grip type)	1010 (10)	13	HN** (High neck)	DS-3** (3-in.) DS-6** (6-in.) DS-8** (8-in.) DS-13** (13-in.)		
ABGPR						

*Stainless steel available on ABR only. **No chain unless specifically ordered.

***Dip stick markings available (minimum order and extra charge).



Removable basket unit



Lockable cap

TANK FILLER-BREATHERS

ALL-NYLON TOP-MOUNTING UNITS

This is an alternative to the traditional metal tank filler. It is made entirely of injection-molded, glass-filled nylon, which provides an attractive, tough, non-rusting product. A strainer basket with 30-mesh equivalent openings is provided.

It will fit into the same size hole as the metal units, and they share the same screw hole pattern.

Nylon breathers are offered only with a 10-micron rated air filter, and in only one basket depth. Mounting hardware supplied. (Stainless steel screws and dipsticks are available.)

TO ORDER, SPECIFY

Standard model
MODEL NO. NAB-1010-4

Weatherproof model
MODEL NO. NABG-1010-4-WP*

Anti-Slosh model (See Catalog DCK)
MODEL NO. NAB-1010-4-AS

*Not stocked

For molded nylon parts made to your specs, call Flow Ezy. Baskets also available separately.



Nylon weatherproof cap

UNITS FOR PRESSURIZED TANKS

These units provide air flow at 25 scfm to displace liquid at the rate of 190 gpm. They have a pressure rating of 5 psi (10 psi optional). It is available in either the standard mount or with the optional "High-neck" mount, which keeps the bottom of the air filter three inches above the tank top. The four-inch deep strainer basket is made of nylon, and has openings equivalent to 30-mesh. The grip-type cap is made of plated steel, and has a 10 or 40-micron air filter.

A safety chain is supplied on the standard model; if desired on the high neck model it must be specified.

To help prevent tampering the cap and mount can have welded lugs to allow use of a padlock. Specify "padlock adapted".

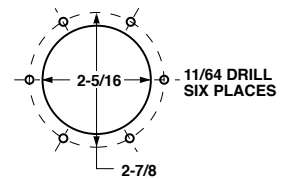

TO ORDER, SPECIFY

Standard model
NO. ABGP-1000-4
(40-micron)
NO. ABGP-1010-4
(10-micron)

High-neck model
NO. ABGP-1000-4-HN
(40-micron)
NO. ABGP-1010-4-HN
(10-micron)

Available with lockable cap, add "-LL" at end of model no.

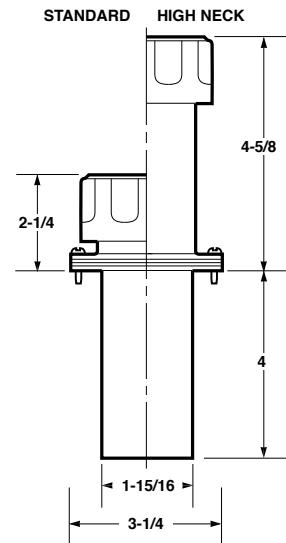

Grip type cap

SIDE-MOUNTING UNITS

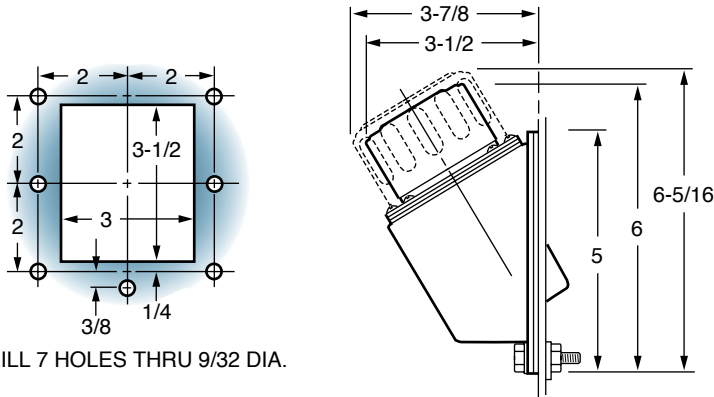

DRILL 7 HOLES THRU 9/32 DIA.

Where top surfaces are not available for locating a filler port, this unit mounts on vertical tank walls. The housing is tough, glass-reinforced nylon. It's only available with a 3-in. deep basket (and optional inner guard). The only other options are the 3-in. dipstick, the lockable cap, and powder coated cap.

HOW TO ORDER SIDE-MOUNTED UNITS

Select the desired specifications from the ordering table and build an ordering code number, as shown in this example:

AM - 1100 - 3 - G - LL - DS - BPC
 CAP - ELEMENT - BASKET - GUARD - Lockable - Dipstick - Black Powder Coated (omit if not wanted)

CAP Type	ELEMENT (Micron)	BASKET Depth (in.)	Inner GUARD	Lock Lugs	Dipstick*	Black Powder Coated Cap
AM (std)	1100 (40)	3 (only)	no symbol (no guard)	LL	DS	BPC
AMG (grip type)	1110 (10)		G (guard)			

*No chain unless specifically ordered.



Black powder coated lockable Cap



Shown with grip type cap

TANK BREATHERS

STANDARD UNITS

These devices ensure a free flow of air into hydraulic tanks or similar containers, while stopping the entry of airborne contaminants. Both 40-micron and 10-micron rated elements are offered in most models. They permit air passage at up to 25 scfm. They have NPT bases.

BF Models. Available in all-steel or nylon-base construction. The nylon-base unit is more than strong-enough, and it costs less.

BFG MODELS. Available with a steel plated grip cap and steel base in 3/4". Both 10 and 40 micron available.

NBF Models. These are of all-nylon construction, and have larger than usual threaded bases, up to 1-1/2 in. NPT. They can be used in ports large enough to serve also as filling openings. Nylon dipsticks are optional; just add "dipstick" to the model number. A weatherproof cap is another option; add "WP" at end of model number. For splash proof cap; add "SP" at end of model number.

PRESSURIZED TANK BREATHER

Allows air flow to 30 cfm and available in either 10 or 40 micron with a 5 psi relief valve setting (3 psi and 10 psi available with special order). Available in 3/4" NPT with a steel base and a grip cap made of plated steel.

ORDER BY PART NUMBER

TYPE	FILTER (Micron)	NPT (In.)	MODEL NUMBER
Nylon Base	40	3/8	BF-2041
		1/2	BF-2042
		3/4	BF-2043
	10	3/8	BF-2011
		1/2	BF-2012
		3/4	BF-2013
Steel Base	40	1/4	BF-2140***
	40	3/4	BF-2143
	40	3/4	BFG-2143
	40	3/4	BFGP-2143*
	10	3/4	BF-2113*
	10	3/4	BFG-2113*
	10	3/4	BFGP-2113*
All Nylon**	10	1/4	NBF-2010***
		3/8	NBF-2011
		1/2	NBF-2012
		3/4	NBF-2013
		1	NBF-2014
		1-1/4	NBF-2015
		1-1/2	NBF-2016

* 3 and 5 psi in stock. 10 psi is not stock.

** Add "WP" at end of model no. for weatherproof top.

Add "SP" at end of model no. for splash proof top.

***Dipstick not available.

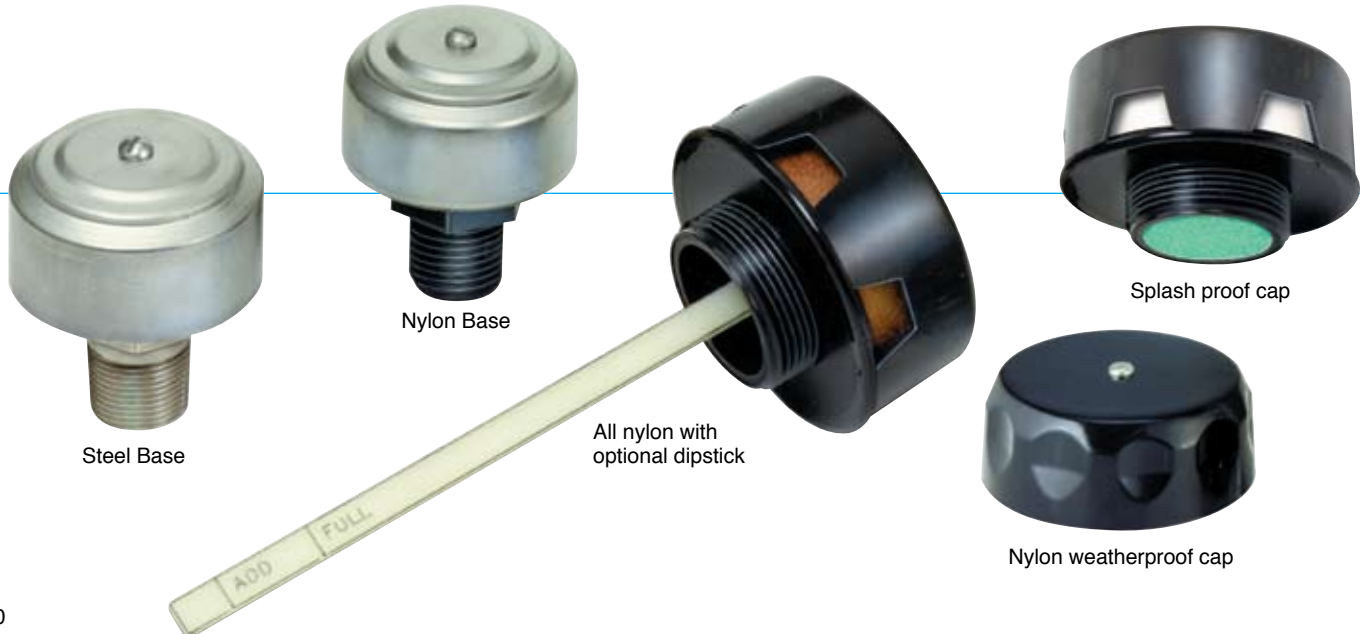
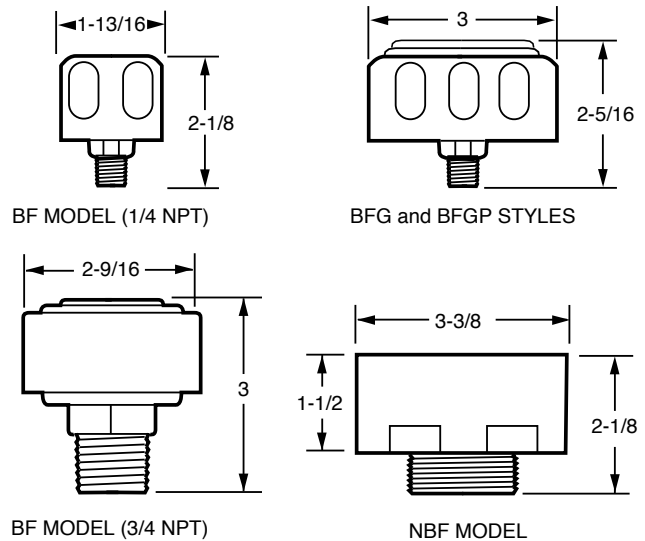

SPIN-ON FILTER ELEMENTS MAKE BIG TANK BREATHERS

Get better filtration of air entering your larger hydraulic tanks, plus much longer filter life, by utilizing 3-, 10-, or 25-micron spin-on hydraulic filters as great big tank breathers (TBAB also available at 149-micron).

We offer a choice of three simple adapters to do the job:

- They all have nipples with straight threads on one end to attach to the filter can.
- TBA has NPT threads on the other end to go into a flange welded to the tank top.
- TBAF has an integral half-coupling for mounting.
- TBAB has a bayonet (gas cap) for mounting.

We sell you black-oxide steel adapters and high-quality spin-on elements at low, low prices.

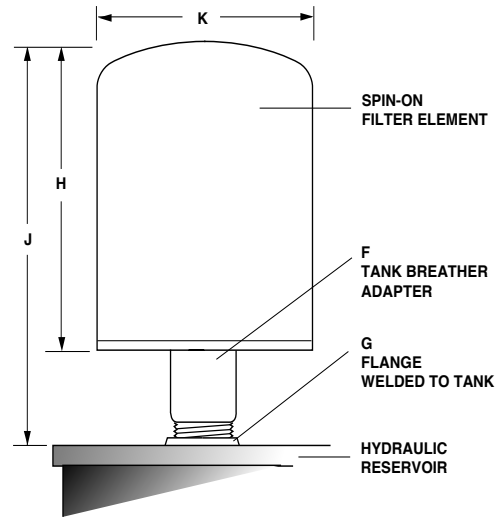

ORDER BY PART NUMBER

SPIN-ON FILTER ELEMENTS

Micron Rating	Part No.	F NPT	G	H	J (approx)	K
3	FEE-30-3	TBA-12	3/4	5-1/4	7-1/4	3-11/16
	FEE-51-3	TBA-20	1-1/4	6-7/8	9	5-1/16
10	FEE-7-10	TBA-08	1/2	3-3/8	5-1/8	3-1/16
	FEE-30-10	TBA-12	3/4	5-1/4	7-1/4	3-11/16
	FEE-51-10	TBA-20	1-1/4	6-7/8	9	5-1/16
25	FEE-7-25	TBA-08	1/2	3-3/8	5-1/8	3-1/16
	FEE-30-25	TBA-12	3/4	5-1/4	7-1/4	3-11/16
	FEE-51-25	TBA-20	1-1/4	6-7/8	9	5-1/16

TANK BREATHER ADAPTERS - Threaded

Part No.	A	B	C (NPT)	D	E
TBA-08	2-3/16	7/16	1/2	3/4-16 UNF	2-214
TBA-12	2-1/2	1/2	3/4	1-12 UNF-2A	2-212
TBA-20	3	1/2	1-1/4	1-1/2-16 UN-2A	2-220

TANK BREATHER ADAPTERS - With Flange

Part No.	A	B	C	D	E
TBAF-08	2-3/16	7/16	3-1/4	3/4-16 UNF	2-214
TBAF-12	2-1/2	1/2	3-1/4	1-12 UNF-2A	2-212
TBAF-20	3	1/2	3-1/4	1-1/2-16 UN-2A	2-220

TANK BREATHER ADAPTERS - Bayonet Cap

Part No.	A	B	C	D	E
TBAB-08	2	7/16	2-1/2	3/4-16 UNF	2-214
TBAB-12	2	9/16	2-1/2	1-12 UNF-2A	2-212
TBAB-20	2-3/8	7/16	2-1/2	1-1/2-16 UN-2A	2-220

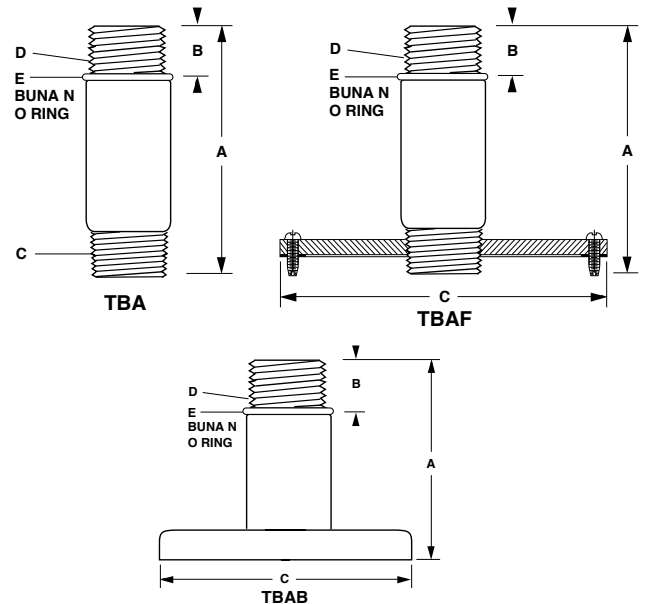

TBAB Bayonet



Spin-On filter element

GIANT TANK BREATHERS

These over-sized units stop airborne dirt from entering tanks as liquid is removed. They provide clean, filtered air fast to replace liquids going out at high rates - up to hundreds of gallons per minute.

Giant tank breathers screw into NPT ports up to 3 inches in size. The threaded base is of nylon, which is strong, lightweight, and seals well against metal. (4-inch models with steel bases are also available; minimum order is twelve.) The strong, steel cover protects the filter elements.

A wide selection of filter elements is offered. They are pleated to increase surface area and dirt holding capacity, and are supported by coarse wire mesh. Elements rated 40 micron and finer are made of synthetic or cellulose (paper) material. Those rated 74 and 149 microns are of stainless steel wire mesh. Elements are easily replaced and replacements are always available.

DIMENSIONS (inches)

Style	A	B
BF-2017	5-13/16	6-1/2
BF-2018	7	8-1/4
BF-2019	7	8-1/4
BF-2020	7	8-1/4

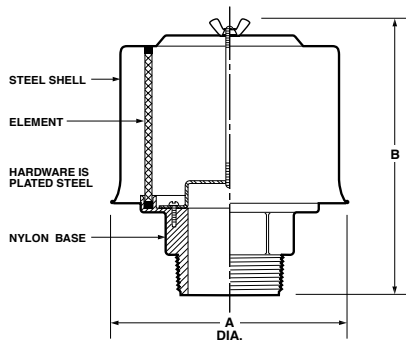

HOW TO ORDER

Select the style number and the element micron-rating you want and combine them.

Example: **Style BF-2017 plus element 10C would be ordered as BF-2017-10C**

SIZE NPT (in.)	STYLE NO.	MICRON RATING†
2	BF-2017	10C
2-1/2	BF-2018	20C 40A
3	BF-2019	74W
4*	BF-2020	149W

* Metal base

†“C” means cellulose, “A” means synthetic, and “W” means wire cloth.

REPLACEMENT ELEMENTS

Micron Rating	For Style BF-2017 Part No.	For Style BF-2018, 9, & 20 Part No.
10C	7827	7807
20C	7827-01	7807-01
40A	7827-02	7807-02
74W	7828	7826
149W	7828-01	7826-01



BACK-PRESSURE INDUCERS

These devices eliminate the need for expensive components to induce hydraulic back pressure, as well as the misapplication of other components, such as check valves, for the same purpose.

When installed in a heat-exchange bypass line, the inducer will limit the pressure of the fluid flowing into the heat exchanger. They can be used to maintain a required return line back-pressure. Many other uses are possible.

HOW TO ORDER

PI	-	8	-	12	-	15
MODEL	-	FEMALE NPT	-	MALE NPT	-	VALVE RATING
STYLE	FEMALE NPT	MALE NPT	VALVE RATING			
PI	2 (1/4) 4 (1/2) 6 (3/4) 8 (1) 10 (1-1/4) 12 (1-1/2) 16 (2)	8 (1) 10 (1-1/4) 12 (1-1/2) 16 (2) 24 (3)	3 (3 PSI) 5 (5 PSI) 15 (15 PSI)			

Standard size combinations are those shown side-by-side (6-10, 8-12, 10-16, 16-24). Any feasible size combinations may be ordered, but they're not stocked (4-12, 8-16, etc).

DIMENSIONS (approximate)

MALE THREAD	A	B	C
1	1-1/2	1	3/4
1-1/4	1-13/16	1-1/4	1-1/8
1-1/2	2	1-5/16	1-3/8
2	2-9/16	1-5/16	1-1/4
3	3-1/4	1-5/8	1-1/4

PRESSURE DROP (approximate)

LINE SIZE (in.)	3/4		1		1-1/4		2	
VELOCITY (fps thru schd. 40 pipe)	10	20	10	20	10	20	10	20
FLOW RATE (gpm)	17	34	27	54	47	94	105	210
SPRING RATING (cracking pressure, psi)	PRESSURE DROPS (psi)							
3	14	39	7	16	5	23	6	23
5	16	41	9	18	6	25	8	25
15	45	70	17	30	14	40	26	60

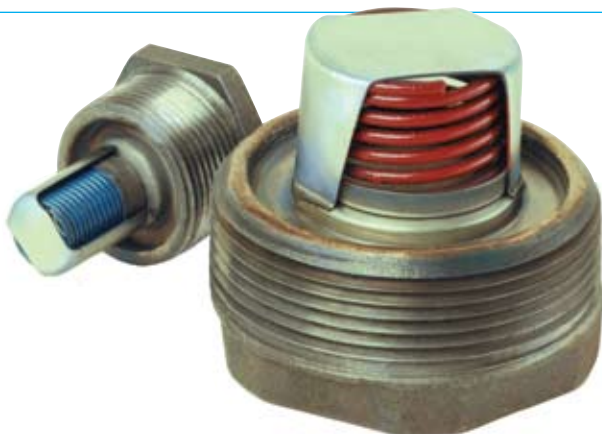

JET MUFFLERS

- 1/8 TO 1-INCH NPT
- SUPERIOR NOISE REDUCTION
- EASILY DISASSEMBLED
- FAIL SAFE PREVENTS EXCESSIVE BACK PRESSURE BUILDUP
- MINIMAL PRESSURE DROP
- RUGGED PLASTIC CONSTRUCTION

Jet Pneumatic Exhaust Mufflers provide superior exhaust noise control and are available in two patented configurations, the TM and SLM Series.

They use a multi-layered, wire mesh element that is impervious to solvents, and easily removed for cleaning.

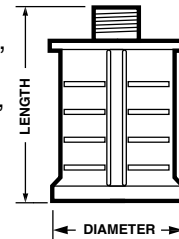

DIMENSIONS (inches)

MODEL	PIPE SIZE	DIAMETER	LENGTH
TM-1	1/8	1.62	1.76
TM-2	1/4	1.62	1.76
TM-3	3/8	2	2.83
TM-4	1/2	2	2.94
TM-6	3/4	2.92	4.15
TM-8	1	2.92	4.38
SLM-1	1/8	.95	2.35
SLM-2	1/4	.95	2.48
SLM-3	3/8	1.34	3.55
SLM-4	1/2	1.34	3.68
SLM-6	3/4	1.90	5.60
SLM-8	1	1.90	5.85

HOW TO ORDER

PIPE SIZE NPT (in.)	MODEL	
1/8	TM-1	SLM-1
1/4	TM-2	SLM-2
3/8	TM-3	SLM-3
1/2	TM-4	SLM-4
3/4	TM-6	SLM-6
1	TM-8	SLM-8

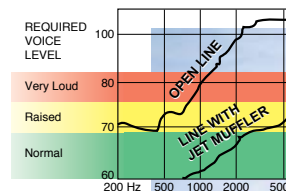

SPIN-ON FILTERS

- FLOWS TO 60 GPM
- PRESSURES TO 150 psi
- STANDARD CAN THREADS
- DIE-CAST ALUMINUM HEADS

These are industry-standard filters; the replacement elements will fit the heads of other major manufacturers (and vice versa). The smaller model FEF-30 cans will interchange with those of U.S. manufacturers, and the larger Model FEF-51 cans will interchange with those of U.S. and some European suppliers.

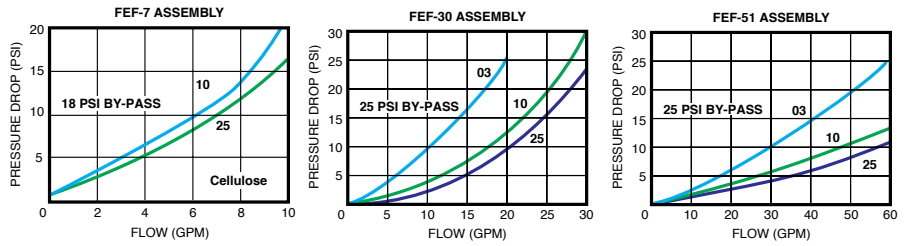

Typical pressure drop through clean filter assembly with oil viscosity of 150 SUS

	FILTER MODEL		
	FEF-7	FEF-30	FEF-51
A	3.05	3.75	5.15
B	1.29	2.87	2.58
C	4.5	7.28	9.56
D	.5	.63	1.5
G	3.05	3.86	5.04
H	1.50	1.50	1.87
L	1/4-20	1/4-20	5/16-18
M	1.12	1.52	2.40
Weight	13 oz	1.75 lb	4.0 lb

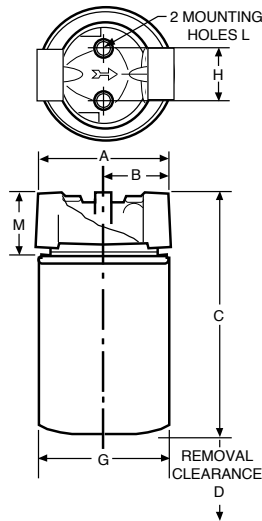

MODEL FEF-51
Element area 950 sq. in.
Flows up to 60 GPM (return)

MODEL FEF-7
Element area 117 sq. in.
Flows up to 7 GPM (return)



MODEL FEF-30
Element area 510 sq. in.
Flows up to 25 GPM (return)

HOW TO ORDER COMPLETE FILTERS

Select the desired specifications from the ordering table and build an ordering code number, as shown in this sample:

FEF - 30 - 12 - 10 - RV25
STYLE - SIZE - PORT - ELEMENT - VALVE

STYLE	SIZE	PORTS	ELEMENT	BYPASS VALVE
FEF	7	04 (1/4 NPT)	03 (3 micron)* 10 (10 micron) 25 (25 micron)	RV-25 (25 PSI) size 30-51
		06 (3/8 NPT)		
	30	12 (3/4 NPT)		
		12S (1-1/16-12 SAE)		
	51	20 (1-1/4 NPT)		
		24 (1-1/2 NPT) 20S (1-5/8-12 SAE)		
			0 no RV	

*Not available on FEF-7, bypass for FEF-7 is located inside element.

HOW TO ORDER REPLACEMENT ELEMENTS

Select the desired specifications from the ordering table and build an ordering code number, as shown in this sample:

FEE - 30 - 10
STYLE - SIZE - ELEMENT

STYLE	SIZE	ELEMENT	ELEMENT THREAD
FEE	7	*03 (3 micron)	(7) 3/4-16 UNF
	30	10 (10 micron)	(30) 1-12 UNF
	51	25 (25 micron)	(51) 1-1/2-16 UNF
		**100 (100 mesh)	

*Not available on FEE 7. **Available in FEE 30, 51 only

HOW TO ORDER SPIN-ON HEADS

Select the desired specifications from the ordering table and build an ordering code number, as shown in this sample:

FEH - 30 - 12 - RV25
STYLE - SIZE - PORT - VALVE

STYLE	SIZE	PORTS	BYPASS VALVE
FEH	7	04 (1/4 NPT)	RV-25 (25 PSI) size 30-51
		06 (3/8 NPT)	
	30	12 (3/4 NPT)	
		16 (1-1/16-12 SAE)	
	51	20 (1-1/4 NPT)	
		24 (1-1/2 NPT) 20S (1-5/8-12 SAE)	
		0 no RV	

*Bypass for FEH-7 is located inside element.

REUSABLE MAGNETS

FOR USE WITH SPIN ON FILTERS

The Bear Trap line of reusable filter magnets are designed to remove ferrous metal particles from hydraulic fluids, oil, fuel, coolant water and transmission fluids. Removes particles the filter doesn't catch. Prevents downstream system damage by trapping metal particles in filter. When changing the element, after removing from the system, remove the magnet from the "can" and attach it to the new element. For use with all brands of disposable filters including those used on domestic and foreign motor vehicle engines, racing engines, diesel engines, transmissions, marine engines, motorcycle engines, hydraulic systems, fuel filters, and coolant filters.

Two sizes available - BT500 (2-1/4" sq.) and BT800 (3" x 6").

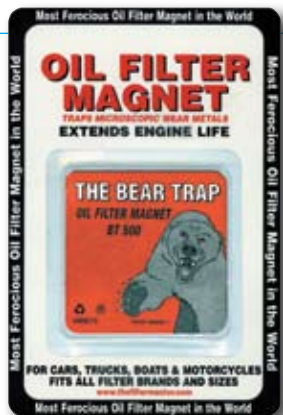

REPLACEMENT LUBE FILTERS

This high-quality, in-line lubricant filter replaces units by Purolator, Cincinnati Milacron, and Danly, at substantial savings. It finds wide application in filtering lubricant and coolant on machine tools, and for many other tasks.

The sealed metal canister contains a high-density, pure cellulose filter element with over 400 square inches of filtering area. Standard element is rated for 10 micron.

MANUFACTURER'S EQUIVALENT PART NUMBERS

PORT SIZE NPT	Purolator	Cincinnati Milacron	Danly Machine	ORDER FLOW EZY NO.
1/4	L-12 21560 683104	219666	58-32-63043	FL-12
3/8	L-15 24616 6683157	222148		FL-15
1/2	L-14 22795 6683140	225470	58-32-630	FL-14

PORT SIZE NPT	LENGTH IN.	PART NO.
1/4	5-7/8	FL-12
3/8	6-3/8	FL-15
1/2	6-5/16	FL-14

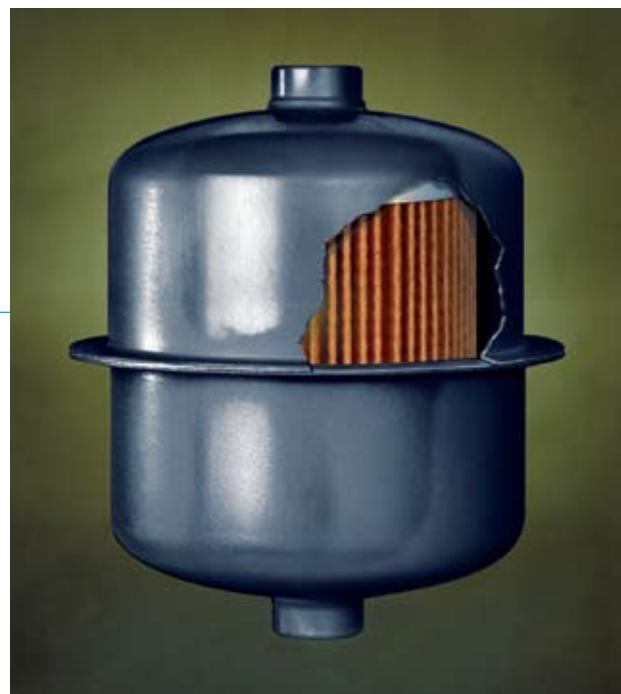
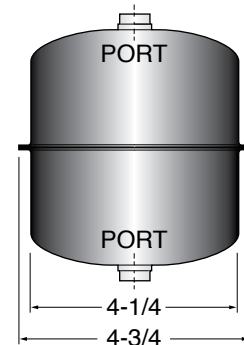

300 PSI INLINE FILTERS

We have the highest quality materials, competitive pricing, and a huge inventory with overnight shipping available. There are more models available than listed here, call for a Motorsport catalog.

Model ILA



HOW TO ORDER

Select the desired specifications from the ordering table and build an ordering code number, as shown in this sample:

MODEL CODE
REPLACEMENT SCREENS

4ILA - 03 - 74 - F3 - RD
 MODEL - SIZE - MICRON - SEALS - COLOR

8286-02
 PART NO.

MODEL NUMBER	CONNECTION SIZE	MICRON SIZE	SEALS	COLOR	PART (MICRON)
ILA	02 (1/4-in.NPT) 6T (3/8-in.TUBE)	238	No Symbol Buna N	RD Red	6180-01 (238)
		149			6180-05 (149)
		74	F3 Viton	BK Black	6180-02 (74)
		40			6180-03 (40)
		25			6180-09 (25)
10	6180-10 (10)				
4ILA	02 (1/4-in.NPT) 03 (3/8-in.NPT) 04 (1/2-in.NPT)	595	F3 Viton	BL Blue	8286-30 (595)
		238			8286 (238)
		149			8286-01 (149)
		74			8286-02 (74)
		63			8286-03 (63)
		40			8286-04 (40)
25	8286-05 (25)				
10	8286-10W (10)				
14ILA	04 (1/2-in.NPT) 06 (3/4-in.NPT) 08 (1-in.NPT)	595	F3 Viton	BK Black	8731-30 (595)
		238			8731 (238)
		149			8731-01 (149)
		74			8731-02 (74)
		63			8731-03 (63)
		40			8731-04 (40)
		25			8731-05 (25)
		10			8731-25 (10W)
		10C			8731-11 (10C)
		5C			8731-20 (5C)
08G	8731-23 (08G)				
03G	8731-22 (03G)				

Pressure Rating: 300 PSI
 Housing Material: Anodized Aluminum
 Colors Available: Black, Blue, Red

Pleated Screen: Stainless Steel
 Flow Rate: Up to 2 GPM
 Filtration Area: 1 Square Inch
 Weight: 3 Ounces
 Dimensions: 1/4 NPT: 1.75 x 1-in.
 3/8-in. Tube Size 6: 2.88 x 1-in.

Pleated Screen: Stainless Steel
 Flow Rate: Up to 4 GPM
 Filtration Area: 20 Square Inches
 Weight: 6.6 Ounces
 Dimensions: 4-21/32 x 1-1/2-in.

Pleated Screen: Microglass, Cellulose, Stainless Steel (Stainless Steel Elements)
 Flow Rate: Up to 14 GPM
 Filtration Area: 60 Square Inches
 Weight: 1 Pound 2 Ounces
 Dimensions: 7-25/32 x 2-1/8-in.



Model 4ILA

Model 14ILA

MOUNTING CLAMPS

Clamps are "tailor made" for in-line filters. Made of stainless steel, with thermoplastic elastomer bushings tough enough to withstand temperatures up to 300°F.

ORDER BY PART NUMBER

MODEL NUMBER	PART NUMBER
4ILA	024M028-SS
14ILA	034M040-SS

Clamps
 Shown on
 Page 28

LOW-COST IN-LINE FILTERS

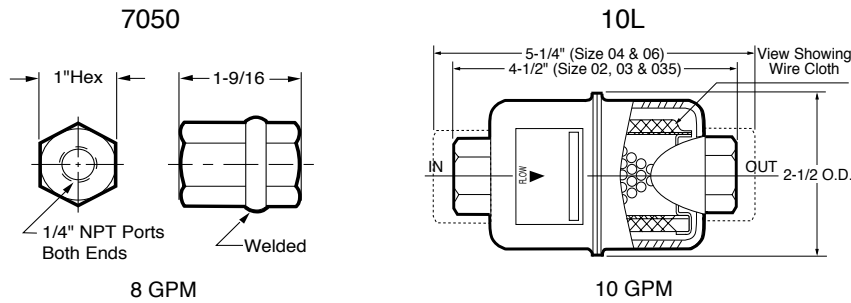

FOR 8 GPM

The 7050 In-Line Filter is rated at 8 gpm. Stainless steel wire cloth elements are cleanable by backflushing.

FOR 10 GPM

The 10L In-Line Filter is rated at 10 gpm (suction), 200 psi operating pressure, these filters are used on lubrication and hydraulic systems. Stainless steel elements are cleanable by backflushing. Synthetic depth-type elements are for throwaway use, and give finer filtration.

Housings are sealed canisters of carbon steel or stainless steel and contain 50 square inches of element over an inner support tube. Female NPT fittings are at both inlet and outlet. Options available are integral bypass valves and magnetic bands.

HOW TO ORDER - 8 GPM

STYLE	ELEMENT
7050	01 238 Micron
	02 74 Micron
	03 40 Micron
	05 149 Micron
	09 25 Micron
	10 10 Micron

HOW TO ORDER - 10 GPM

Select the desired specifications from the ordering table and build an ordering code number, as shown in this sample:

10L - 03 - 595 - RV-5 - M - CS
 STYLE - NPT - ELEMENT - VALVE - MAGNETS - MATERIAL
 (omit if not wanted)

STYLE	NPT (Pipe)	ELEMENT (Mesh or Micron)	VALVE (Optional)	MAGNETS (Optional)	MATERIAL
10L	02 (1/4)	Stainless Wire:	RV-3 (3-psi)	M	CS Carbon Steel
	03 (3/8)	585	RV-5 (5-psi)		
	04 (1/2)	238	RV-15 (15-psi)	SS* Stainless	
	06 (3/4)	149			
	03S (3/4-16)	74			
		40			
		25			
		Synthetic:			
		15A (micron)			
		40A (micron)			

*Available in 06 size only



Style 10L



Style 7050

1500 and 3000-PSI IN-LINE FILTERS

For 238, 149 and 74.
 .75 (1.5 IN. Hg) pressure drop
 at 150 SUS viscosity fluid.

6IL rated at 5 GPM (suction).
 15IL rated at 15 GPM (suction).
 These filters can also be used
 for higher return flows. Here
 higher pressure drops (to 350
 psi) can usually be tolerated and
 finer micron ratings are possible
 depending on element pore size
 and fluid viscosity. Their sturdy
 machined-aluminum, steel, or
 stainless steel housings give
 them the strength to be pressure
 rated at 1500 or 3000 psi.

These units use pleated
 elements made from either
 stainless steel wire cloth or
 cellulose (paper), with a
 perforated metal support tube
 inside. These elements can
 be easily removed for cleaning
 or replacement. (They can not
 be cleaned by backflushing
 while in the housing.)

REPLACEMENT ELEMENTS 350 PSID

MICRON RATING	6IL PART NO.	15IL PART NO.
REINFORCED ΔP ELEMENTS		
595	8504-595	8560-595
238	8504	8560
149	8504-01	8560-01
74	8504-02	8560-02
40	8504-04	8560-04
25	8504-05	8560-05
10W	8286-10W	
05C	8504-20	8560-20
10C	8504-11	8560-11
03G	8504-22	8560-22
08G	8504-23	8560-22

6IL & 15IL U-BRACKETS

TO FIT	FLOW EZY NO.
6ILA & 6ILS 6ILSS	026M030 026M030-SS
15ILA & 15ILS 15ILSS	038M044 038M044-SS

	6IL	15IL
A	4-15/16	6-5/16
B	1-3/8	2
C	1-5/8	2-3/8
D	1-1/2	2-1/8

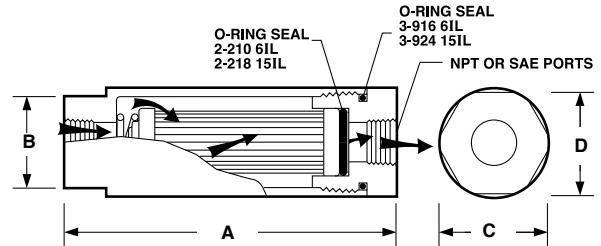

HOW TO ORDER

Select the desired specifications from the ordering table and build an ordering code number, as shown in this sample:

6ILA - **03** - **74** - **F3** - **U**
 STYLE - PORTS - ELEMENT - SEALS - BRACKET
(omit if not wanted)

STYLE	PORTS		ELEMENT† (Micron)	SEALS	BRACKET
	NPT	SAE			
6ILA (Aluminum, 1500 psi) 6ILS (Steel, 3000 psi) 6ILSS (Stainless Steel, 3000 psi)	03 (3/8)	03S (3/4-16) (UNF-2B) 04S (7/8-14)	Stainless wire: 595 238 149 74 40 25 10*	no symbol (Buna N) F3 Viton	U
	04 (1/2)				
	06 (3/4)				
	08 (1)				
	08 (1-5/16-12) (UNF-2B)				
15ILA (Aluminum, 1500 psi) 15ILS (Steel, 3000 psi) 15ILSS (Stainless Steel, 3000 psi)	06 (3/4)	06S (1-1/16-12) (UNE-2B) 08S (1-5/16-12) (UNF-2B)	Cellulose: 5C 10C Micro-glass: 03G 08G		
	08 (1)				

†Other element ratings available on request *Available on 6IL only.



Shown with optional U-Bracket

CARTRIDGE FILTER HOUSING



This design has been a standard in the industry for over 40 years. The housing is available in either carbon steel or stainless steel. Maximum operating pressure is 250 psi and standard operating temperature is 275°F. This housing is available with 1" NPT connections only.

DESIGN FEATURES

- Designed for industrial and commercial filtration applications
- Heavy duty construction for durability
- Offered in carbon steel or 304 stainless steel
- Simple nut and bolt design for quick cartridge change outs
- In-line fittings for easy installation
- Knife edge seal at both cartridge ends to eliminate bypass
- Designed for double open end cartridges
- 1" NPT pipe size standard
- 1/8" NPT drain port on bottom of housing

TYPES OF CARTRIDGES AVAILABLE

- Flow Ezy's all stainless steel industrial process cartridges
- Flow Ezy's A2 model fabric wound 9-7/8" cartridges
- Flow Ezy's meltblown 9-7/8" cartridges
- Any other 9-7/8" double open end cartridge with an ID of 1-1/8" and an OD of no larger than 3"



**Order Cartridges
on pages
30, 31, and 32**

HOW TO ORDER

Order by model number:

MODEL NUMBER	DESCRIPTION
FAC788	Carbon steel
FAS788	304 stainless steel

MELTBLOWN CARTRIDGES

Meltblown nonwovens are highly engineered fabrics made of fine synthetic fibers that have been thermally bonded to form a web structure. Filtration is the fastest growing end use market for nonwovens, both liquid and air. This is a process for producing fibrous webs directly from polymers using high velocity air to soothe the filaments.

We offer a full range of pleated filters with meltblown polyester and polypropylene media. These cartridges provide high solid loading capacity and long service life. Where cost efficiency is a must, choose our meltblown filter cartridges.

- Filtration levels are available in 1,3, 5, 10,20,30, and 40 micron.
- End cap configuration options are double open end, single open end, single open end with aligning fin, and single open end with either double -222 or -226 o-rings. We can also supply plastisol end caps in double open end.
- The core is polypropylene.
- Standard OD of all cartridges is 2-1/2 inch.
- The temperature rating of the cartridges is 225°F /105°.
- Pressure rating is 150 psi with the recommended pressure drop for servicing rated at 35 psid max.



HOW TO ORDER

Build an ordering code as shown in this example:

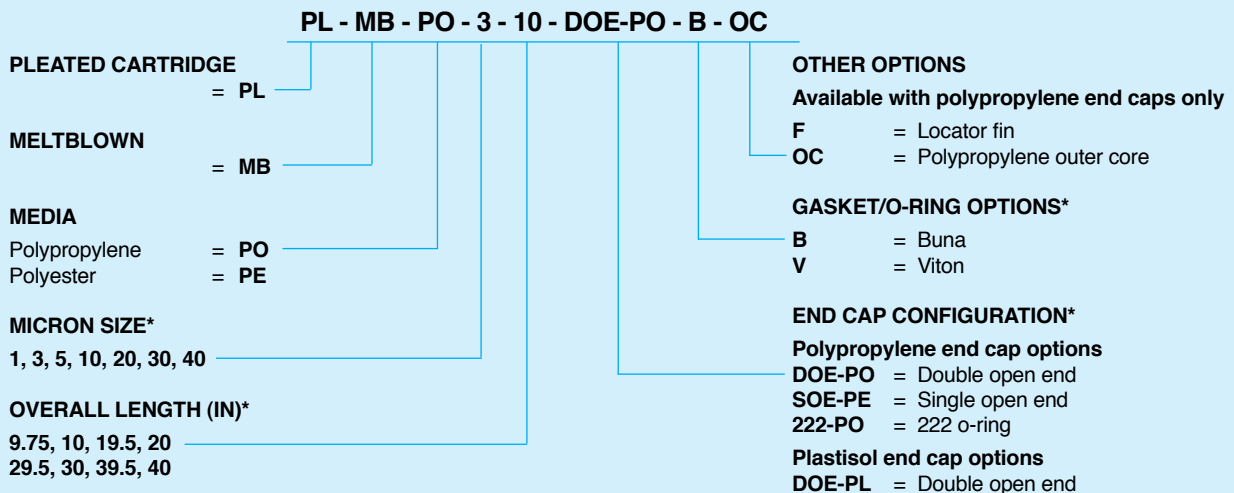

*Other micron sizes, lengths, end cap configurations and gasket/o-ring options may be available

INDUSTRIAL PROCESS FILTER CARTRIDGES

Fits most cartridge-type housings

Overcome the temperature and compatibility limitations of fabric or synthetic fiber cartridges by replacing them with these stainless steel wire cloth elements. They are good up to 500 degrees F, instead of the usual 250 degrees F, and they are unaffected by most caustic fluids.

Made entirely of 304 or 316 stainless steel, they are cleanable and reusable, and can withstand differential pressures up to 60 psi (500 psid units are available). You can choose particle retention ratings as fine as 5 microns.

Element surface is pleated to increase surface area. Units rated at 100 microns or finer have an underlying support layer of coarser mesh to prevent pleat collapse. Fabrication is by welding and crimping; no silver brazing or epoxy bonding is used.

HOW TO ORDER

Build an ordering code as shown in this example:

30 - 75 - P - B - S - DOE

CARTRIDGE LENGTH		
9-3/4	19-1/2	29-1/2
9-7/8	20	30
10		

MICRON RATING		
840	190	75
540	150	40
370	120	20
280	100	10
230	80	5

CONSTRUCTION	
Pleated	= P
Cylindrical	= C*

END CONFIGURATION	
DOE	= Double open end, with seals

ELEMENT MATERIAL	
S	= 304 stainless steel
S316	= 316 stainless steel

SEAL MATERIAL	
B	= Buna N
E	= Ethylene Propylene
V	= Viton®
T	= Teflon®

*Not a stock item

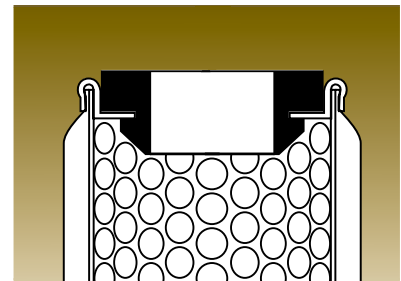
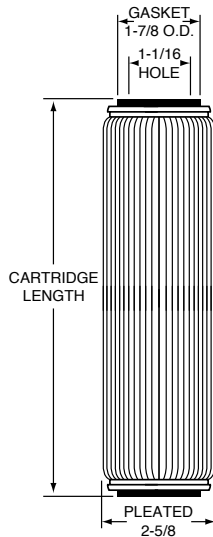

Flow Ezy seals are generally not glued onto the cartridge ends as is commonly done. Instead, they are specially shaped to hold on place mechanically, like a grommet. There is little chance they will be dislodged and lost in handling. They are made in different thicknesses to provide seven different standard overall element lengths.



A²-SERIES CARTRIDGE FILTER ELEMENTS

Flow Ezy now offers true depth-filtration, continuous-wound cartridge elements in a wide range of materials, lengths, and micron retention ratings. A highly innovative single-core design is used, eliminating the "joints"

common in other manufacturers' elements at 10-inch intervals. Available materials include cotton, acrylics, nylon, rayon, and polypropylene. Element lengths range from 9-3/4 inches to 40 inches, fitting most cartridge filter

housings. Micron retention ratings are from 200 down to 0.5 micron. These elements offer true depth filtration, higher efficiency, lower pressure drop and greater solids holding capacity than standard elements, at a very competitive price.

HOW TO ORDER A²-SERIES FILTER CARTRIDGES

Select the desired specifications from the ordering table and build an order code number, as shown in this example:

CU - **15.0** - **R** - **30** - **A**
 MEDIA - MICRON - DIAMETER - LENGTH - CORE MATERIAL

FILTER MEDIA	MICRONS (NOMINAL)	DIAMETER (NOMINAL)	LENGTH (NOMINAL)	CORE MATERIAL
CU (Natural Cotton)	100.0	R (2.5")	40	S (304 Stainless Steel)
	75.0		39.5	
	50.0		39	
C (White Cotton)	30.0		30	A (316 Stainless Steel)
	25.0		29.5	
	20.0		20	
P (Polypropylene)	15.0		19.5	T (Tin-Plated Steel)
	10.0		10	
	5.0		9.75	
PE (Polyester)				P (Polypropylene)

Note: Other media and micron sizes available by special order.



If our standard cartridges do not meet your specific requirements, consult the factory for availability of cartridges that will.

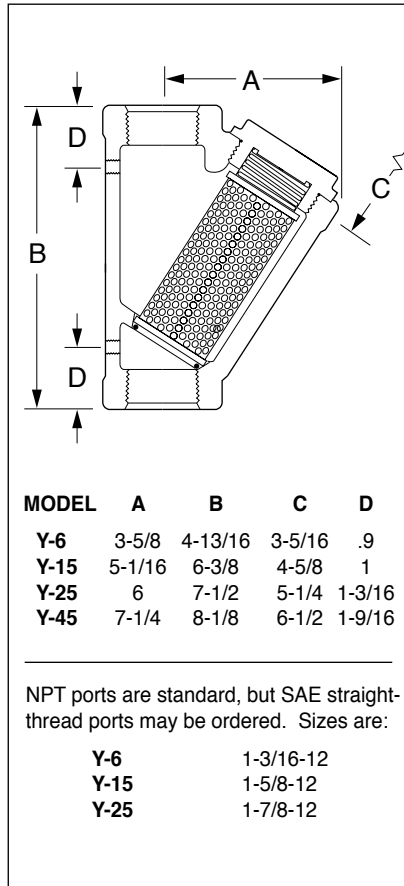

EFFICIENT, EASILY-CLEANED FILTERS, AT THE LOWEST POSSIBLE PRICE

These filters are built on the proven design of the common "Y" strainer, but instead of a coarse screen, they contain a true micron-rated filter element whose pleated element surface area is up to four times greater. In fact, the filtering area in the "Y" filter design is equal to that found in standard hydraulic filters, but at a fraction of the cost!

The flow path in the "Y" design is through the inside surface of the element, where the contaminant is caught. There can be no dirt "wash-off" of the element downstream during servicing. This also minimizes the formation of air pockets within the filter element.

Many other styles are available. Ask for our Catalog DCK.

OPTIONS

See How To Order for dirt indicator, magnets, and built-in bypass.

HOW TO ORDER

Use the flow rate table to select the proper model number and build an ordering code as shown in the example.

EXAMPLE: Y - 15 - ST - 149 - F3 - 2 - M - S

FILTER MODEL

PIPE SIZE SYMBOL

NPT	SAE (ST)	SYMBOL
3/4	1-3/16-12	Y-6
3/4	1-3/16-12	Y-6SS*
3/4	1-3/16-12	Y-6AL**
1-1/4	1-5/8-12	Y-15
1-1/2	1-7/8-12	Y-25
2	2-1/2-12	Y-45

ELEMENT (Micron rating)

595
238
149
74
40
25

SEAL

Buna N = No symbol
Viton = F3

*Stainless Steel **Aluminum

INDICATOR

No symbol = No indicator
S = Suction line indicator
SM = Suction, with memory
R = Return line indicator

MAGNETS

No symbol = No magnets
M = Magnets (except Y-6)

BYPASS VALVE

2 = 2 psi
3 = 3 psi
5 = 5 psi
15 = 15 psi

FILTER ELEMENT AREAS

Model	Pipe Size, NPT	Element Area, Sq.-In.
Y-6	3/4	17
Y-15	1-1/4	56
Y-25	1-1/2	84
Y-45	2	125

ELEMENT NUMBERS

Y6-595	6179-30	Y25-595	6184-30
Y6-238	6179	Y25-238	6184
Y6-149	6179-01	Y25-149	6184-01
Y6-74	6179-02	Y25-74	6184-02
Y6-40	6179-04	Y25-40	6184-04
Y6-25	6179-05	Y25-25	6184-05
Y15-595 - 6208-30		Y45-595 - 8860-30	
Y15-238	6208	Y45-238	8860
Y15-149	6208-01	Y45-149	8860-01
Y15-74	6208-02	Y45-74	8860-02
Y15-40	6208-04	Y45-40	8860-04
Y15-25	6208-05	Y45-25	8860-05

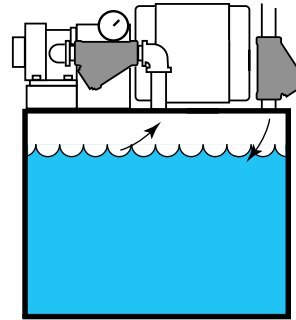

Typical Suction and Return line installations.



Y2 Filter Element

Y2 FILTER

The Y-2 is a tiny powerhouse. Rated at 250 PSI and constructed of 316 stainless steel, this unit finds wide application in both suction and return line service. It's available in connection sizes of 1/4", 3/8" and 1/2" NPT. The stainless steel elements are available in 595, 238, 149, 74, 63, 40 and 25 micron.

Screen:	Stainless Steel
Flow Rate:	Up to 2 GPM
Filtration Area:	2.5 Square Inches
Weight:	8 Ounces
Dimensions:	2-1/2 x 2-1/4-in.

HOW TO ORDER

Select the desired specifications from the ordering table and build an ordering code number, as shown in this sample:

MODEL CODE	REPLACEMENT SCREENS
Y2 - SS - 1/4 - 149 - F3	
MODEL - MATERIAL - CONNECTION - MICRON - SEALS	PART NO.

MODEL NUMBER	HOUSING MATERIAL	CONNECTION SIZE (NPT)	MICRON SIZE	SEALS	PART (MICRON)
Y2	SS (Stainless Steel)	1/4-in.	595	No Symbol Teflon	6177-01 (595)
			238		6177-02 (238)
			149		6177-03 (149)
		3/8-in.	74	F3 Viton	6177-06 (74)
			63		6177-04 (63)
			40		6177-07 (40)
			25		6177-05 (25)



Model TF-U-L100 shown in the most frequent T-Filter arrangement.

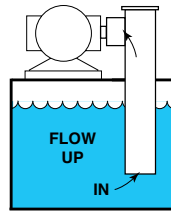

On an L-shaped reservoir, a TF-D-S50 T-Filter is used to filter the suction line to the pump.

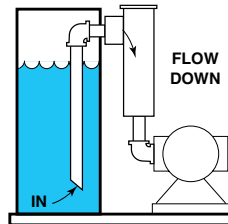

An open-bottomed Model TF-D-L45 filters fluid as it returns to the tank.

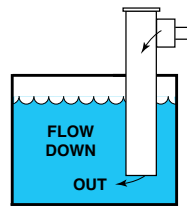

Model TF-D-S23 serves here as a return-line filter.

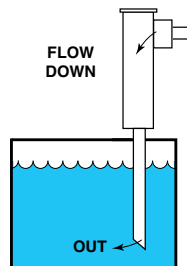

SENSIBLE, HIGH-CAPACITY, HIGHLY-VERSATILE FILTERS

The T-Filter concept is to provide large-area (low pressure drop) filter elements, that are easily replaced, in low-cost housings made of welded steel tube. Elements can be cleanable wire mesh or throw-away fiber.

Install inside or outside the tank. Eliminate the usual pipe between tank and filter, and one pipe elbow.

Two element lengths available. Long elements in housings with unthreaded bottoms are usually specified for in-tank installations. The long elements also come in housings with threaded bottoms for piped installations.

For lower capacity or more compact installations, a series of short elements are available, in housings with threaded bottom ports only.

Two element designs. One for "flow-up" and one for "flow-down" filtering.

Easy element servicing. Elements lift straight up out of the clean-out port, which also serves as a filling port.

FILTER ELEMENT RATINGS AND AREAS

SYMBOL	DESCRIPTION	RATING, um		SQUARE INCHES OF ELEMENT PER MODEL						
		Nominal	Absolute TF-P12	TF-L12 TF-P18	TF-L18 TF-P45	TF-L45 TF-P100	TF-L100	TF-S9	TF-S23	TF-S50
238	Stainless steel wire, 60 mesh	238	-	120	230	315	460	115	157	230
149	Stainless Steel wire, 100 mesh	149	-	120	230	315	460	115	157	230
74	Stainless steel wire, 200 mesh	74	-	120	230	315	460	115	157	230
40A	Synthetic fiber (single layer)	50	85	N/A	150	360	680	75	180	340
15A	Synthetic fiber (double layer)	42	70	N/A	110	280	510	60	150	250
20C	Cellulose fiber	23	65	N/A	223	580	1200	110	285	500
10C	Cellulose fiber	13	30	N/A	223	580	1200	110	285	500

T-FILTERS®

Open-bottomed T-Filter is shown with a long flow-up type element.

T-Filter with a threaded port at the bottom is shown with a short flow-down type element.

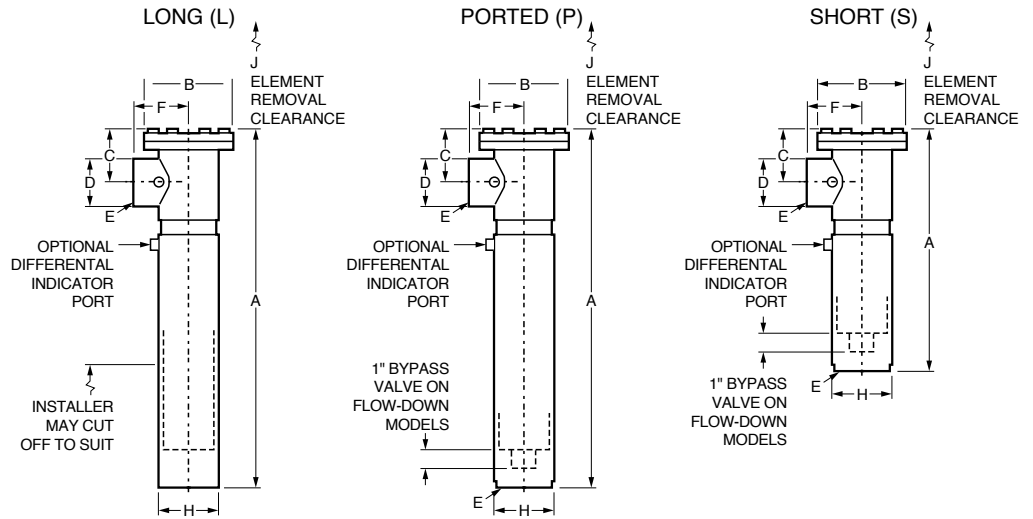
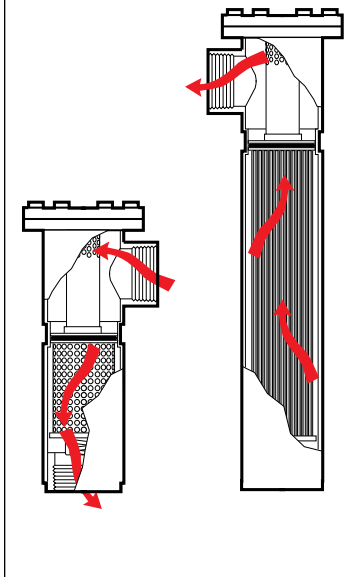

DIMENSIONS

FILTER MODEL	A LENGTH	B DIA.	C	D DIA.	E NPT	F	G	H	J
L12	20-1/2	3-1/8	2-3/8	1-5/8	1	2-1/2	18-1/8	1-7/8	19
L18	24-1/2	3-5/8	2-1/2	2	1-1/4	2-3/4	22	2-3/8	20
L45	26-1/2	4-5/8	3	2-3/4	2	3-1/4	23-1/2	3-1/2	21
L100	30-1/2	5-3/4	3-5/8	4	3	4-1/4	26-15/16	4-1/2	22
P12	21	3-1/8	2-3/8	1-5/8	1	2-1/2	18-11/16	1-7/8	19
P18	25	3-5/8	2-1/2	2	1-1/4	2-3/4	22-9/16	2-3/8	20
P45	27-1/16	4-5/8	3	2-3/4	2	3-1/4	24-1/8	3-1/2	21
P100	31-3/4	5-3/4	3-5/8	4	3	4-1/4	27-13/16	4-1/2	22
S9	14-1/2	3-5/8	2-1/2	2	1-1/4	2-3/4	12-1/16	2-3/8	13
S23	15-1/4	4-5/8	3	2-3/4	2	3-1/4	12-1/4	3-1/2	13
S50	17-1/8	5-3/4	3-5/8	4	3	4-1/4	13-5/8	4-1/2	14-1/2

HOW TO ORDER

EXAMPLE: TF - U - L100 - 74 - F3 - 3 - M - S

FILTER SERIES

T-Filter = TF

FLOW DIRECTION

Up = U

Down = D

FILTER MODEL

Long element, open (non-threaded) bottom

L12, L18, L45, L100

Long element, ported (threaded) bottom

P12, P18, P45, P100

Short element, ported (threaded) bottom

S9, S23, S50

ELEMENT

Cleanable wire mesh

238, 149, 74

Throwaway type

15A, 40A, 20C, 10C

INDICATOR

No Symbol = No indicator

S = For Suction Line

SM = Suction with memory

R = For Return Line

DP = Pressure differential indicator

MAGNETS

No Symbol = No magnets

M = Magnets

BYPASS VALVE

No Symbol = No valve

3 = 3 psi

5 = 5 psi

15 = 15 psi

25 = 25 psi

SEALS

No Symbol = Buna N

F3 = Viton

For effective low-cost, high volume filtration

Suction Line Filter Selection

Suction filters, the most important filter in the entire system, protects the the key system component, the pump. A single TEXAS Filter can clean hundreds of gallons of fluid per minute.

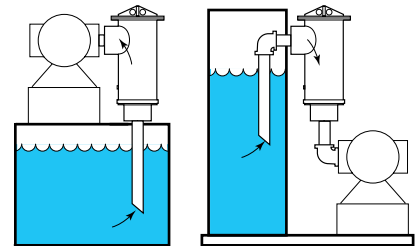

Return Line Filter Selection

TEXAS Filters provide an ideal way to pre-condition fluid to higher levels of cleanliness before it returns to the reservoir. (Return line filter covers are made stronger for the higher pressures found in these applications.)

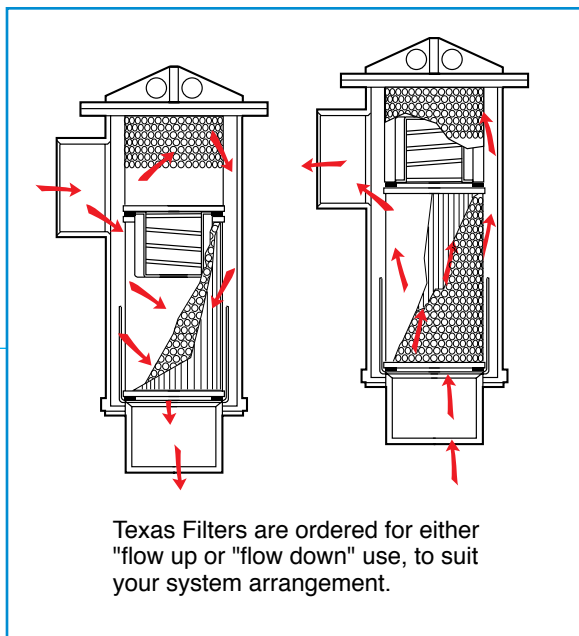
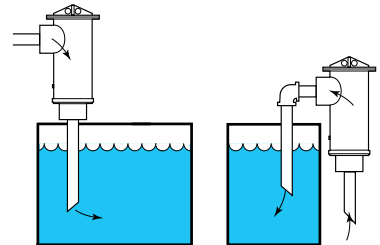

ELEMENT DIMENSIONS				
MODEL	O.D.	I.D.	LENGTH	AREA
TXF-75 6847 (OBS)	4-1/4	3-1/8	5-5/8	275
TXF-100 6348	4-1/2	3-1/8	7-1/2	375
TXF-150 6349 (OBS)	5-7/8	4-7/8	8	500
TXF-200 6350	5-7/8	4-7/8	10-3/4	650
TXF-300 6351 (OBS)	5-7/8	4-7/8	15-3/4	1000
TXF-400 6352	8-1/8	7-1/8	15	1200

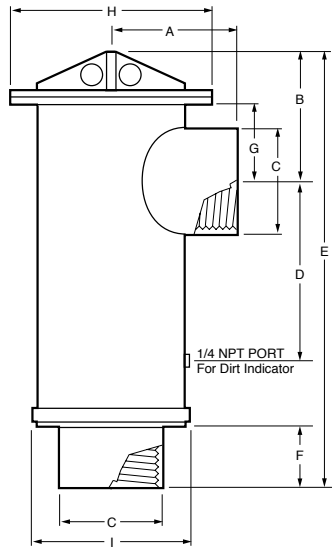

DIMENSIONS

MODEL	USAGE	PIPE SIZE	A	B	C	D	E	F	G	H	I
TXF-100	SUCTION	3	5.31	4.81	4.00	4.38	15.50	2.69	2.69	7.31	5.88
	RETURN	1-1/2	4.71	3.81	2.20	5.38	14.25	1.44	1.69		
TXF-200	SUCTION	4	6.62	5.31	5.00	5.5	20.12	2.88	3.19	9.88	8.12
	RETURN	2-1/2	6.79	4.44	3.25	6.38	19.75	2.50	2.31		
TXF-400	SUCTION	6	7.36	6.44	7.39	6.5	26.00	3.38	4.31	11.88	10.25
	RETURN	4	7.83	5.31	5.00	7.62	25.50	2.88	3.19		

HOW TO ORDER

EXAMPLE: TXF-200 - S - U - F - 74 - F3 - RV3 - M - SM

FILTER MODEL

TXF-100

TXF-200

TXF-400

USAGE

SUCTION = S

RETURN = R

FLOW DIRECTION

UP = U

DOWN = D

PORT STYLE

FEMALE NPT COUPLING = F

ELEMENT MICRON RATING

595

238

149

74

40W

25

40A

DIRT INDICATOR

NO SYMBOL = NO INDICATOR

S = FOR SUCTION LINE

SM = SUCTION WITH MEMORY

R = FOR RETURN LINE

MAGNETS

NO SYMBOL = NO MAGNETS

M = MAGNETS

BYPASS VALVE

RV3 = 3 PSI

RV5 = 5 PSI

RV15 = 15 PSI

SEALS

NO SYMBOL = BUNA N

F3 = VITON

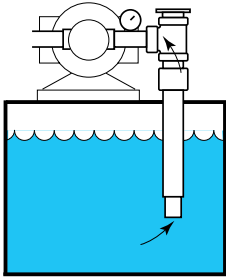

SUCTION LINE Typical installation shows how pipe acts as a housing around filter element. Standpipe does not entirely enclose the TU-series element: it need only extend to below minimum fluid level of the tank. A vacuum gage may be mounted just ahead of pump to indicate differential pressure across the filter.

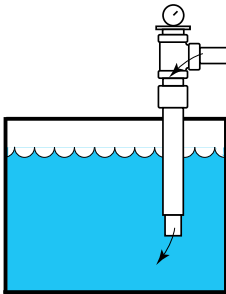

RETURN LINE Typical installation shows that piping set-up is similar to suction line installation: The only difference is that the TD-series element is used, to handle flow "down" rather than "up".



PIPE UP LOW-COST FILTERS WITH TEE-EZY, AND SAVE UP TO 60%

That's right! With your piping our Tee-Ezy kit, you'll have a true filtering system (down to 3 micron) for slightly more than you're now paying for a common sump strainer and the same amount of pipe, fittings and labor, plus:

- You can clean and replace the filtering element without draining the tank or taking apart piping.
- You can monitor filter dirt build-up by adding a dirt indicator.
- Optional bypass valves are built in to product the system from a dirt-clogged filter.
- You can filter suction or return lines.

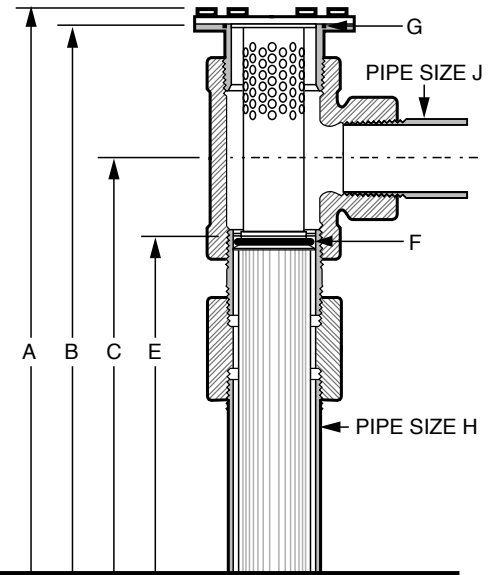

DIMENSIONS

FILTER SIZE	ELEMENT PORE SIZE	A OVERALL LENGTH*	B ELEMNT	C LENGTH*	D END CAP O.D.	E MEDIA LENGTH	F O-RING SPECS: DASH NO. / X-SECTION	G	H	J
TS-12	ALLL	19-1/4	18-3/4	16	1.385	14	220/.139	137/.103	1-1/2	1
TS-18	60,100,200	19-7/8	19-3/8	16-3/8	1.835	14	225/.139	144/.103	2	1-1/4
	ALL OTHERS	19-7/8	19-3/8	16-3/4	1.835					
TS-45	60,100,200	21-1/4	20-3/4	16-3/4	2.234	14	233/.139	153/.103	3	2
	ALL OTHERS	21-1/4	20-3/4	16-3/4	2.864					
TS-100	60,100,200	23-3/4	23-1/4	18-3/8	2.862	14	241/.139	247/.139	4	3
	ALL OTHERS	21-1/4	20-3/4	16-3/4	2.864					

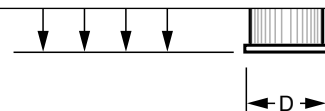

TEE-EZY™ FILTERS

INSTALLATION

When laying out assembly:

1. Be sure there's clearance to remove the element assembly from the piped housing. For size 12, 18 and 45, you'll need 22 inches, and for size 100, 25 inches.

2. In suction-line applications, pipe flow comes in at the end, or from all sides (Fig. 1 and 2). Don't let flow impinge against one side only (Fig. 3). The more exposed an element, the longer it will serve without clogging.

3. Use standard schedule 40 pipe and 125-psi pressure service fittings.

The important O-ring seal:

To prevent fluid from bypassing the element, an O-ring is used to seal the space between the cartridge and the pipe housing. Because the I.D. of schedule 40 pipe may vary beyond the sealing range of the O-ring, a properly sized and machined nipple can be ordered. It is threaded into the bottom of the tee.

If you don't wish to use the nipple, use any schedule 40 pipe that you can seal with the O-ring (see O-ring specs), and give it the proper internal chamfer, to compress the O-ring. See Fig. 4. (Always lubricate O-ring before inserting cartridge.)

4. If you use the pre-machined nipple, you must file an entry bevel of about 15° by 1/8 in. on the I.D. of the standpipe. The I.D. of the pipe must be such that the O-ring seals against it.

5. To install the clean-out port in your tee fitting, a simple wrench adapter like that shown is easily made up.



1.



2.



3.



4.



5.

PERFORMANCE

TEE-EZY Size Designation	Filter Element Pore Size	GPM @ 1 P.S.I.D.*
TS-12	60, 100 or 200 Mesh (74 μm)	12
TS-18	60, 100 or 200 Mesh (74 μm)	18
	15 or 40 Micron	14.8
	20 Micron	9.7
TS-45	60, 100 or 200 Mesh (74 μm)	45
	40 Micron	39
	20 Micron	25
	15 Micron	38
	10 Micron	5
TS-100	60, 100 or 200 Mesh (74 μm)	100
	40 Micron	74
	20 Micron	62
	15 Micron	71
	10 Micron	12
	3 Micron	8

* Pounds per square inch differential pressure, using 150 SSU viscosity oil. All figures were developed using clean elements and standpipes that extended beyond end of element cartridges. Recommended piping, that exposes end of cartridge (as shown in drawings), would provide higher flows at same pressure differentials.

HOW TO ORDER

First, build an ordering code for the clean-out port and cover, as in this example:

TS - 18 - N - F3
Style - Size - Nipple - Viton O-Ring

STYLE	SIZE	NIPPLE	O-RING
TS	12 18 45 100	N (nipple with machined I.D. for good O-Ring seal)	No Symbol = Buna N F3 = Viton

Second, build an ordering code for the replacement element assembly, as in this example:

TU - 18 - 74 - RV3 - F3
Style - Size - Element - Valve - Viton O-Ring

STYLE	SIZE	ELEMENT GRADE (Micron Size)	BYPASS	O-RING
TU (Flow up for suction line)	12	238 micron 149 micron 74 micron	RV3 (3-psi)	No Symbol = Buna-N
	18	149 micron 74 micron	RV5 (5-psi)	
TD (Flow down for return line)	45	40 micron, synthetic	RV15 (15-psi)	F3 = Viton
	100	20 micron, cellulose 15 micron, double syn. 10 micron, cellulose	RV30 (30-psi)	
	45 100	3G 3 micron, micro glass		

MODELS 4, 6, 8 High-Capacity Strainers and Filters

Strainers or Bag Filters for Hydraulic Fluids and Other Oils

Strainer/filter housings are made in many sizes, and all can serve as basket strainers (for particle retention down to 74 micron size) or as bag filters (for particle retention down to 1 micron size). In all cases, covers are easily removed, without tools, and the basket or bag is easily cleaned or replaced.

FEATURES

- Large-area, heavy-duty baskets
- Low pressure drops
- Housings are permanently piped
- Covers are O-ring sealed
- Carbon steel, or stainless steel (304 or 316) housings
- All housings are electropolished to resist adhesion of dirt and scale
- Adjustable-height legs, standard on Models 6 and 8; optional extra on Model 4
- Easy to clean
- Liquid displacers for easier servicing (optional)

These filters meet the more exacting needs of hydraulic and lubricating fluid filtration.

Construction Materials

All housings and other wetted parts not otherwise specified can be ordered in carbon steel, 304 stainless steel, or 316 stainless steel. Four different materials can be ordered for all seals involved. All baskets and mesh linings are made of stainless steel. 304 stainless steel will be supplied with carbon and 304 housings, 316 stainless with 316 housings.

Choose a basket strainer or bag filter

Once the choice between straining a fluid (removing particles down to one 74 micron size) and filtering it (removing particles down to one micron) has been made, the choice of which size Flow Ezy filter model must be made. All three models (4, 6 and 8) and the baskets and bags that go in them, are of the same basic design. They differ in dimensions, capacities, maximum pressure ratings, and pipe size. Selection is based on these variables.

Pressure Drop

Basket strainers and bag filters are usually selected so that the pressure drop does not exceed 2 psi, when they are clean. Higher pressure drops may be tolerated when contaminant loading is low. That pressure drop information is accurate for all housings with strainer or filter bag baskets only. When filter bags are added, the total pressure drop becomes the sum of the existing pressure drop plus the pressure drop through the bag. Consult the factory for the formula to determine the pressure drop for your application.



Additional sizes are available. Ask for our Bag Filter Catalog.

MODELS 4, 6, 8 High-Capacity Strainers and Filters

OPERATION

Unfiltered liquid enters the housing above the bag or basket and passes down through them. Solids are contained inside the bag or basket where they're easily and completely removed when the unit is serviced. A hinged basket bail is pushed down by the closed cover, to hold the basket against a positive stop in the housing. It helps prevent bypassing of unfiltered liquid.

Fluid bypass around the basket is prevented by an optional O-ring seal between the basket rim and the housing ID. This seal is required on Model 8 bag filters. Model 4 and 6 bag filters don't need this O-ring because the OD of the filter bag seals against the housing itself, rather than against the ID of the basket rim.

A single cover gasket is used to seal the opening, and covers can be installed and removed without tools.

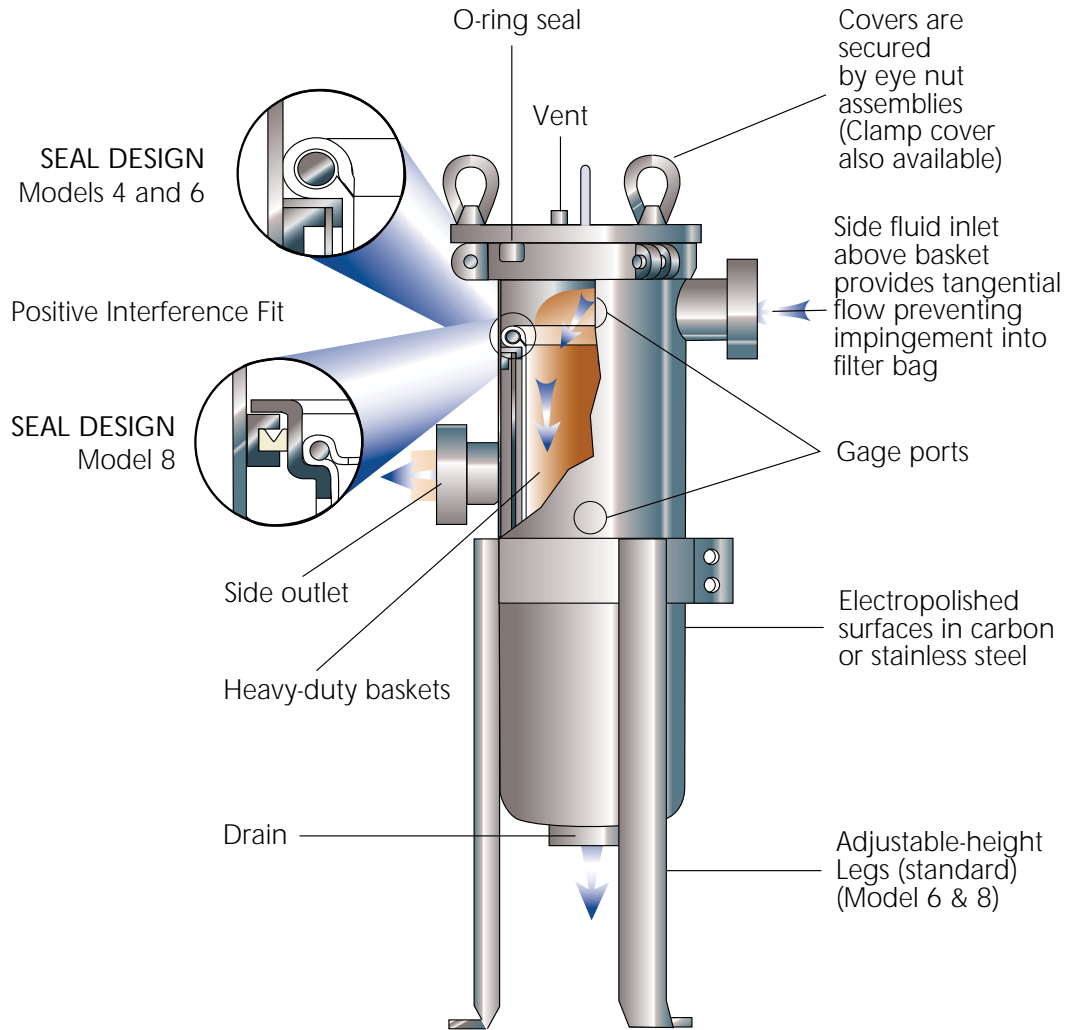

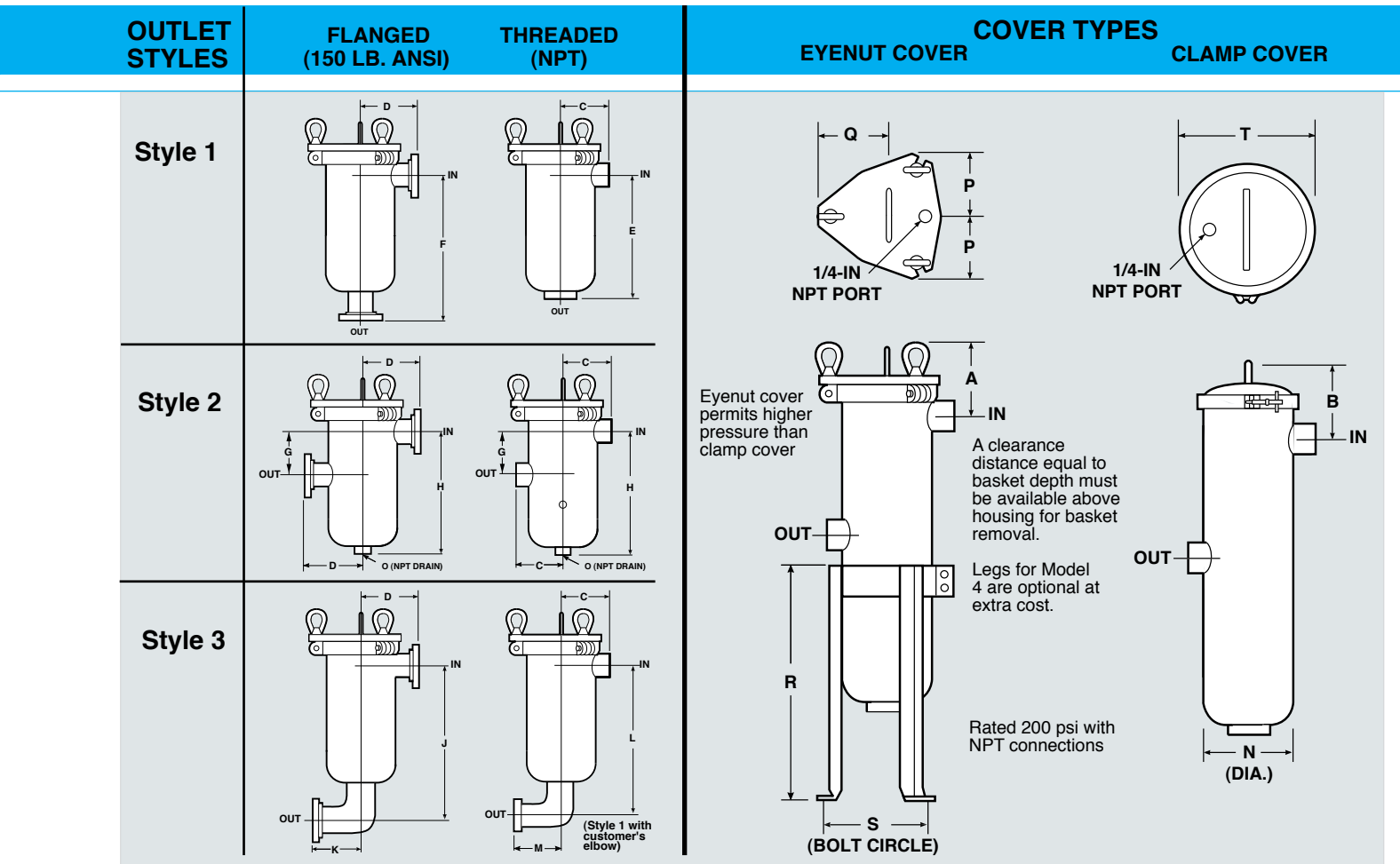

DIMENSIONS (inches)

Model	Pipe Size	A	B	C	D	E	F	G	H	J	K	L	M	N	O	P	Q	R	S	T	
4-6	3/4	5.5	5.2			10.1	12.0	3.0	10.1	10.4		11.2	1.3								
	1	5.5	5.2			10.1		3.0	10.1	10.9		11.5	1.5								
	1-1/4	6.0	5.8	3.5	5.0	9.4	12.0	4.3	9.5	10.5	4.0	11.1	1.8	4.5	1/2	3.5	3.6	14.0	6.8	5.6	
	1-1/2	6.0	5.8			9.3		4.3	9.5	10.8		11.3	2.0								
	2	6.0	5.8			9.3		4.3	9.5	11.6		11.8	2.3								
4-12	3/4	5.5	5.2			16.1		3.0	16.1	16.4		17.2	1.3								
	1	5.5	5.2			16.1		3.0	16.1	16.9		17.5	1.5								
	1-1/4	6.0	5.8	3.5	5.0	15.4	18.0	4.3	15.5	16.5	4.0	17.1	1.8	4.5	1/2	3.5	3.6	14.0	6.8	5.6	
	1-1/2	6.0	5.8			15.3		4.3	15.5	16.8		17.3	2.0								
	2	6.0	5.8			15.3		4.3	15.5	17.6		17.8	2.3								
6-12	1	6.1		4.3		17.3	19.8	4.3	17.3	18.1	5.0	18.6	1.5								
	1-1/4	6.1		4.3		17.3	19.8	4.8	17.3	18.4	5.0	19.0	1.8								
	1-1/2	6.1	N/A	4.3	6.0	17.3	19.8	4.8	17.3	18.8	5.0	19.3	2.0	6.0	3/4	5.0	5.3	18.0	9.5	N/A	
	2	6.1		4.3		17.2	19.7	4.8	17.3	19.6	5.0	19.7	2.3								
	3	7.0		4.4		18.2	20.7	6.6	18.2	22.0	4.8	21.9	3.1								
6-18	1	6.1				23.3	25.8	4.3	23.3	24.1	5.0	24.6	1.5								
	1-1/4	6.1				23.3	25.8	4.8	23.3	24.4	5.0	25.0	1.8								
	1-1/2	6.1	N/A	4.3	6.0	23.3	25.8	4.8	23.3	24.8	5.0	25.3	2.0	6.0	3/4	5.0	5.3	18.0	9.5	N/A	
	2	6.1				23.2	25.7	4.8	23.3	25.6	5.0	25.7	2.3								
	3	7.0				24.2	26.7	6.6	24.2	28.0	4.8	27.9	3.1								
6-30	1	5.5				35.3	37.8	4.3	35.3	36.1	5.0	36.6	1.5								
	1-1/4	6.0				35.3	37.8	4.8	35.3	36.4	5.0	37.0	1.8								
	1-1/2	6.1	N/A	4.3	6.0	35.3	37.8	4.8	35.3	36.8	5.0	37.3	2.0	6.0	3/4	5.0	5.3	18.0	9.5	N/A	
	2	6.1				35.2	37.7	4.8	35.3	37.6	5.0	37.7	2.3								
	3	7.0				36.2	38.7	6.6	36.2	40.0	4.8	39.9	3.1								
8-15	2	6.6		5.9	7.5	20.9	23.5	4.8	21.0	23.2	3.3	23.1	2.3								
	3	7.4	N/A	6.8	7.5	36.7	39.6	6.6	36.9	40.5	4.8	40.9	3.1	8.6	1	5.8	6.3	22.0	12.0	N/A	
	4	7.4		6.8	8.6	21.5	25.1	8.4	21.9	26.8	6.3	27.6	3.8								
8-30	2	6.6		5.9	7.5	35.9	38.5	4.8	36.0	38.2	3.3	38.1	2.3								
	3	7.4	N/A	6.8	7.5	39.6	39.6	6.6	36.9	40.5	4.8	40.9	3.1	8.6	1	5.8	6.3	22.0	12.0	N/A	
	4	7.4		6.8	8.6	40.1	25.1	8.4	36.9	41.8	6.3	42.6	3.8								

HOW TO ORDER Build an ordering code as shown in the example

Example: 8-15 -3P- 1-150-C- B-S-M-200-D-C - 2M 50

MODEL NO.

4 = 4
6 = 6
8 = 8

HOUSING SIZE

6 inch = 6 (Model 4 only)
12 inch = 12 (Models 4 & 6 only)
18 inch = 18 (Model 6 only)
15 inch = 15 (Model 8 only)
30 inch = 30 (Models 6 & 8 only)

PIPE SIZE, NPT and FLANGED¹

3/4-in. female NPT = 3/4P
1-in. female NPT = 1P
1-1/4-in. female NPT = 1-1/4P
1-1/2-in. female NPT = 1-1/2P
2-in. female NPT = 2P
3-in. female NPT = 3P
(Models 6 & 8 only)
3/4-in. 150 class ANSI flange = 3/4F
1-in. 150 class ANSI flange = 1F
1-1/4-in. 150 class ANSI flange = 1-1/4F
1-1/2-in. 150 class ANSI flange = 1-1/2F
2-in. 150 class ANSI flange = 2F
3-in. 150 class ANSI flange = 3F
(Models 6 & 8 only)
4-in. 150 class ANSI flange = 4F
(Models 6 & 8 only)
6-in. 150 class ANSI flange = 6F
(Model 8 only)

OUTLET STYLE

Bottom = 1
Side = 2
Bottom elbow = 3

PRESSURE RATING²

150 psi (NPT or flanged) = 150
(Models 6 & 8 only)
200 psi (NPT) (Model LCO4 only) = 200
210 psi (NPT) (Model 6 only) = 210
300 psi (flanged) = 300
500 psi (NPT) (Model 4 only) = 500

HOUSING MATERIAL

Carbon steel = C
304 stainless steel = S
316 stainless steel = S316

COVER GASKET

Buna N = B
Ethylene Propylene = E
Viton® Fluoroelastomer = V
Teflon® Fluorocarbon Resin (300 psi only) = T

OPTIONAL INNER BASKET

FOR MODEL 8 ONLY

OPTIONAL INNER BASKET, MEDIA SIZE-No symbol if type 2B basket was selected

Perforation diameters (for type 2P baskets)
1/4, 3/16, 9/64, 3/32, 1/16

Mesh sizes (for type 2M and 2BM baskets) 20, 30, 40, 50, 60, 70, 80, 100, 150, 200

OPTIONAL INNER BASKET TYPE

2B = Filter bag basket, 9/94 perforations³
2P = Strainer basket, perforated metal
2BM = Filter bag basket, perforated, mesh lined³
2M = Strainer basket, perforated, mesh lined

ASME CODE STAMP

C = Code

DISPLACER

D = Displacer

BASKET, MEDIA SIZE-No symbol if type B basket was selected

Perforation diameters (for type P baskets)
1/4, 3/16, 9/64, 3/32, 1/16

Mesh sizes (for type M and BM baskets)
20, 30, 40, 50, 60, 70, 80, 100, 150, 200

BASKET TYPE

PB = Filter bag basket, 9/64 perforations³
P = Strainer basket, perforated metal
BM = Filter bag basket, perforated, mesh lined³
M = Strainer basket, perforated, mesh lined
HWM = Filter bag basket, heavy wire mesh³

BASKET SEAL

S = Seal required (on strainer type baskets)
N = No seal (with bag type baskets)

HOW TO ORDER FILTER BAGS Build an ordering code as shown in the example

CONSTRUCTION

Felt Bags: Felt construction is generally chosen where smaller particle retention is required, in the 1 to 100 micron range. It offers higher solids loading capacity than mesh. General purpose felt bags are offered in polyester and polypropylene. Mesh bags: Mesh is a woven construction, generally used where micron ratings of 5 to 800 (660 to 20 mesh) are required. Two types are offered.

The **multifilament** mesh is a low cost, disposable material, offered in polyester or nylon.

Monofilament mesh has higher strength, and is available in polypropylene or nylon. It should be considered cleanable.

FELT BAG FINISHES AND COVERS

Standard finish: Plain, as manufactured, without treatment or covers.

Glazed finish: The outermost surface fibers are melted by the momentary application of high heat. This bonds them to one another and effectively reduces the possibility of their breaking off. This finish is not available on high temperature bags.

Mesh Covers: Covers are available that completely encase the bag. Made of woven polyester mesh, nylon mesh, spun-bonded nylon (Cerex), or spun-bonded polyester (Remay), they act to contain any fibers that may separate from the filter bag.

DESIGN DETAILS

All Flow Ezy filter bags have a metal retaining ring at their opening. Standard ring material is cadmium-plated carbon steel, with 316 stainless steel optional. Heavy-duty handles, sewn to the reinforced bag lip, are a standard feature. They make bag removal faster and easier.

NOTE:

- Flanges provided with the housing match the pressure rating of the vessel. Housings rated 150 psi have 150 class flanges. Housings rated 300 psi have 300 class flanges. ANSI B16.5 Pressure-Temperature rating tables determine flange class for ASME code housings. Consult factory.
- Higher pressure ratings available. Consult factory.
- Filter bags are specified separately.

Minimum quantity on non-standard sizes / materials. Consult factory.

Example: PE-25 - P - 7 - S - SS

Fiber and Micron Ratings
Felt, polyester
Microns: 1, 3, 5, 10, 15, 25,
50, 75, 100, 200

= PE

Felt, polypropylene
Microns: 1, 3, 5, 10, 25, 50, 100

= PO

Felt, Oil-Adsorb, 25-micron

= OA 25

Felt, Nomex

= HT

Microns: 5, 10, 25, 50, 100

Felt, Teflon, 10-micron

= TE 10

Mesh, monofilament

= NMO

Microns: 5, 10, 25, 50, 75,
100, 125, 150, 175
200, 250, 300, 400, 600, 800

Mesh, monofilament polypropylene
Microns: 300, 600

= PMO

Mesh, multifilament polyester
Microns: 75, 100, 125, 150, 200, 250,
300, 400, 800

= PEM

Mesh, multifilament nylon (heavy)
Microns: 800

= HNM

Inner Bags for Model 8 or Multibag Filters.

To order inner bags, use a second, separate ordering code. It should be built using the system shown above, but prefixed by the symbol "IN". Example: IN-PE 25 P 2 S-SS

Additional Options

SS = Stainless steel ring

Bag Style

S = Plated ring

Bag Dimensions

Symbol	Dia. (in.)	Length (in.)	Housing Model
1 =	7-1/16 x	16-1/2	8-15
2 =	7-1/16 x	32	8-30
3 =	4-1/8 x	8	4-6
4 =	4-1/8 x	14	4-12
7 =	5-1/8 x	15	6-12
8 =	5-1/8 x	21	6-18
9 =	5-1/8 x	32	6-30
12 =	5-1/4 x	32	LCO

Bag Finish Or Cover

P = None (standard)

G = Fiber-free glazed finish

PEM = Polyester multifilament mesh cover

NM = Nylon multifilament mesh cover

C = Spun-bonded nylon (Cerex) cover

R = Spun-bonded polyester (Remay) cover

FILTER BAG SIZES

USED ON FLOW EZY MODEL NO.	BAG SIZE	LENGTH (inches)	DIAMETER (inches)	SURFACE AREA (sq. ft.)	BAG VOLUME (gallons)
4-6	3	8	4.12	0.5	0.5
4-12	4	14	4.12	1.0	1.0
6-12	7	15	5.10	1.3	1.3
6-18	8	21	5.10	2.0	1.5
6-30	9	32	5.10	3.4	2.8
	1	16.5	7.06	2.0	2.1
8-15	1 (inner)	14.5	5.75	1.6	1.7
8-30	2	32	7.08	4.4	4.5



PLEATED BAGS FOR BAG FILTERS

Flow Ezy's pleated bags give up to 12 times the filtration that normal filter bags do. They are easy to use, too. Also, when removing the dirty cartridge, the contamination does not wash or slide off. They are just like cartridge elements, providing more surface area, thus giving more dirt-holding capacity. When you have a filter that requires frequent changing, pleated bags are the best option.

The seams are not sewn, they are sonically welded to prevent leakage or any contamination bypass. The top sealing flange and the bottom flange are also sonically welded to the pleated cylinder.

The pleated filter bag is made of polyester or polyester micro-fiber media. It has ultrasonic bonded polypropylene end caps. The bottom has an extended polypropylene end with a male, polypropylene threaded bolt.

The pleated filter bag can then be turned clockwise to adjust the height. When the filter is at the proper height, the top flange will seat into the filter bag basket.

With the direction of the flow inside-out, all the pressure is pushing on the exterior walls and bottom of the pleated filter bag. Without the bolt configuration and the seat against the basket, the bottom seal would be broken rendering the filter useless and compromising the integrity of the filter and the health of the system.



BAG SIZE	STD. BAG SQ. FT.	PLEATED BAG SQ. FT.
1	2.3	15.0
2	4.4	25.0
3	0.5	2.9
4	1.0	6.2
7	1.3	8.0
8	2.0	11.5
9	3.4	18.5

HOW TO ORDER

Build an ordering code as shown in this example:

Order Code Example: PL - R2 - POMF - 8 - P2 - QT B

BAG SIZED

PLEATED CARTRIDGE = PL

TOP SEALING RING DESIGN

Flared polypropylene = R1, R2

Solid polypropylene = R3

Flared polypropylene = FSI

HIGH EFFICIENCY MATERIAL

Micro-fiber polyester = PEMF

Micro-fiber polypropylene = POMF

Standard polyester = PE

Standard polypropylene = PO

QT B = Quick Turn Bolt

(only available in sizes 1 and 2)

BAG SIZE

P1 = 7-1/16 x 11-1/8

P2 = 7-1/16 x 26-1/8

P3 = 4-1/8 x 5-1/16

P4 = 4-1/8 x 11-1/16

P8 = 5-5/8 x 16-1/8

P9 = 5-5/8 x 26-3/4

MICRON RATING

1, 3, 8, 19, 35, 48,

55, 65, 70, 90, 110

(see specific style above)

OIL-ABSORBING INSERT CARTRIDGES



If the process fluid in your system is water, there may be a possibility of oil getting into it. This is a simple, inexpensive way to improve the quality of the water in your system. "Oil Absorbing Cartridges" are made of a thick loft, large fiber, polypropylene meltblown media with a polypropylene perforated core. They repel water while absorbing up to 25 times their own weight in oil and other petroleum based fluids. They are also great for cleaning up shop oil spills and removing trace contaminants.

When used in combination with filter bags in a process bag filter housing, it can help keep your system oil free.

Standard are bag sizes 1 and 2. Custom sizes can be made upon request. Standard part numbers are:

ORDER BY PART NUMBER

PART NO.	SIZE
OAC 1	= Size 1 (15" oal, 3" od)
OAC2	= Size 2 (30" oal, 3" od)



HYDRAULIC FLANGES

- 4-BOLT SAE DESIGN
- RATED FOR 3000 PSI PRESSURE
- SEVEN SIZES, 3/4 THROUGH 3-INCH
- FEMALE NPT THREADS



MOUNTING HARDWARE KIT (optional)

O-ring (1),
cap screws (4),
lock washers (4)

HOW TO ORDER FLANGES

Select the desired specifications from the dimension table and order by number, example: **W43-24P**

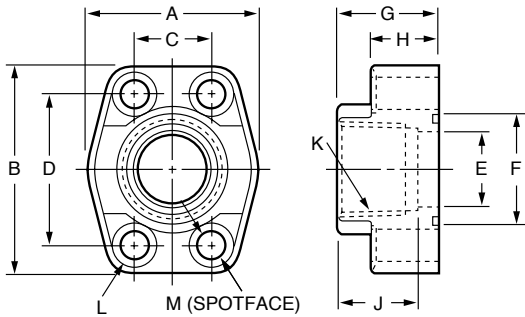

PORTABLE FILTER SYSTEM

Flow Ezy Portable Oil Transfer and Filter System has many applications for use in the plant or in the field

- For fluid transfer from drums or storage tanks to system reservoir
- For fluid conditioning
- For filtering out system oil resulting from failure of system component
- Recirculating system oil without having to shut down
- Removal of water from oil (with optional 3rd stage, 3 micron water removal filter)
- Clean-up contaminated hydraulic oils

Standard filter gives you 2 filters instead of 1. First stage filters at 25 micron and the second at 10. Two models are available, one with a 5 gpm rating and one with a 10 gpm rating. Very economical way to protect the system from damage caused by contamination.



HOW TO ORDER

MODEL	COARSE FILTER	POLISHING FILTER	WITH 3RD STAGE WATER REMOVAL FILTER
JD100 (5 GPM)	25c	10C	
JD110 (10 GPM)	25C	10C	
JD 100 (5 GPM)	25C	10C	3W
JD 110 (10 GPM)	25C	10C	3W
REPLACEMENT ELEMENTS	FEE-51-25	FEE-51-10	LE3AZ

Model Number	Nominal Flange Size	A	B	C ±0.010	D ±0.010	E DIA.	F DIA.	G	H	J	K NPTF Thread	L DIA.	M Spotface	SOC HD CAP SCREW	"O" RING ARP-568 Uniform Dash
W43-12P	3/4	2.06	2.56	0.875	1.875	0.75	1.255 / 1.250	1.25	.84	.87	3/4	.406	.594	3/8-16 x 1-1/2"	-214
W43-16P	1	2.31	2.75	1.031	2.062	1.00	1.565 / 1.560	1.37	.97	1.12	1	.406	.594	3/8-16 x 1-1/2"	-219
W43-20P	1-1/4	2.88	3.12	1.188	2.312	1.25	1.755 / 1.750	1.50	1.03	1.12	1-1/4	.469	.656	7/16-14 x 1-3/4"	-222
W43-24P	1-1/2	3.25	3.69	1.406	2.750	1.50	2.125 / 2.115	1.62	1.09	1.12	1-1/2	.531	.781	1/2-13 x 1-3/4"	-225
W43-32P	2	3.81	4.00	1.688	3.062	2.00	2.500 / 2.490	1.62	1.09	1.12	2	.531	.781	1/2-13 x 1-3/4"	-228
W43-40P	2-1/2	4.28	4.50	2.00	3.500	2.50	3.005 / 2.995	2.00	1.47	1.56	2-1/2	.531	.781	1/2-13 x 1-3/4"	-232
W43-48P	3	5.16	5.31	2.438	4.188	3.00	3.625 / 3.615	2.25	1.59	1.72	3	.656	.937	5/8-11 x 2"	-237

HIGH-QUALITY WIRE CLOTH

Available in square-footage amounts

Our wire cloth is a metal fabric woven from high-quality alloy wires in a variety of opening sizes and wire diameters. The number of openings per inch constitutes the mesh count or size. For example, a mesh count of 24 x 110 signifies 24 openings per horizontal inch, with 110 openings per vertical inch. When shown as a single number, the mesh count indicates distance from center to center of parallel wires, horizontally and vertically. A wide range of mesh sizes and square footage are available in your choice of plain mesh weave, plain-dutch weave or twilled-dutch weave.

Uses include:

- Food Sizing and Processing
- Plating Baskets
- Liquid/Particulate Separation
- Chemical Waste Filtration
- Water and Wastewater Treatment
- Silk Screening
- Pharmaceutical Processing
- Laboratory Cages
- Printed Circuit Board Manufacturing

HOW TO ORDER WIRE CLOTH

Select the desired material and mesh size, as shown in this example: **BRASS, 50x40**

Mesh	Wire Diameter	Width of Opening	% Open Area
ALUMINUM			
18 x 16	0.011		
BRASS			
16 x 16	0.018	0.0445	50.7
24 x 24	0.014	0.0277	44.2
30 x 30	0.011	0.0220	44.9
40 x 36	0.010	0.015/.017	38.3
50 x 40	0.008	0.012/.017	41.0
60 x 50	0.0065	0.0102/.0135	41.4
80 x 70	0.0055	0.0073	22.8
100 x 90	0.0045	0.0055/.0066	32.6
120 x 108	0.0035	0.0050	36.0
BRONZE			
18 x 14	0.011		
150 x 140	0.0026		
150 x 140	0.0026		
STEEL			
16 x 16	0.023	0.0395	39.9
STAINLESS STEEL TYPE 304			
4 x 4	0.035	0.2150	74.0
6 x 6	0.032	0.1320	62.4
8 x 8	0.028	0.0970	60.2
10 x 10	0.025	0.0750	56.3
20 x 20	0.014	0.0360	51.8
30 x 30	0.011	0.0220	44.9
40 x 36	0.009	0.0160	41.0
50 x 40	0.008	0.012/.017	41.0
50 x 246 Twin Warp	0.0045/.0045		
50 x 250 Plain Dutch	0.0055/.0045		
60 x 50	0.0065	0.0102/.0135	41.4
80 x 70	0.0055	0.0073	22.8
100 x 90	0.0045	0.0055/.0066	32.6
120 x 108	0.0035	0.0050	36.0
150 x 140	0.0026		
165 x 800 Twilled Dutch	0.0028/.0018		
200 x 190	0.0021	33.6	
200 x 1400 Twilled Dutch	0.0028/.0016		
325 x 325	0.0014	30.0	
Sheet widths are either 18" or 24". Additional charges for slitting			



PLAIN WEAVE

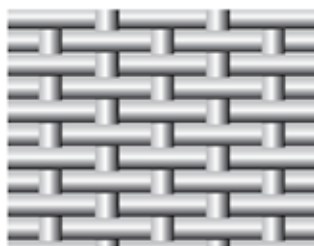

PLAIN-DUTCH WEAVE

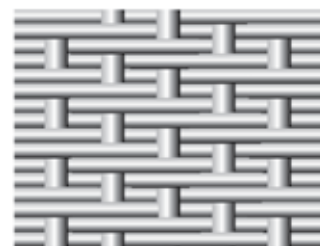

TWILLED-DUTCH WEAVE

REPLACEMENT ELEMENTS

Flow Ezy offers hundreds of replacement elements. The following pages are a cross reference to many elements offered.

We also have mesh sizes not offered by the original manufacturers, and many discontinued designs. If you don't see what you need on the following pages, contact Flow Ezy, we most likely have what you need.

Manufacturer	Page
--------------	------

I. VICKERS	46
II. PARKER	46
Moduflow	60
Pressure Filter	62
Spin-On Filter	62
III. SCHROEDER	63
IV. MARVEL	67



PART NUMBER CROSS REFERENCE

OLD VICKERS NO.	NEW VICKERS NO.	FLOW EZY NO.	VITON (F3) (V3)	O.D.	L	I.D.	DESC.	
228467	(923069)	PL-305-10-10	—	3	4-3/8	—		10µ Cell
228468	(923070)	PL-507-10-10	—	4-5/8	7	—		10µ Cell
361739	(941054)	4697-01	(941055)	2-7/16	3-11/16	1-1/2	10FA	74 µm
361740	(941058)	4698-01	(941059)	4	6-1/4	2-7/8	50F*	74 µm
361741	(941062)	4699-01	(941063)	4	6-1/4	2-7/8	50F*	74 µm
361990	(941052)	4697	(941053)	2-7/16	3-11/16	1-1/2	10FA	149 µm
361991	(941056)	4698	(941057)	4	6-1/4	2-7/8	50F*	149 µm
361992	(941060)	4699	(941061)	4	6-1/4	2-7/8	50F*	149 µm
378990	(941066)	5979-01	(941067)	5-1/2	8-5/8	—	100F*	74 µm
378991	(941064)	5979	(941065)	5-1/2	8-5/8	—	100F*	149 µm
398854	(941070)	PL-308-3-9	(941071)	3	8-1/8	—		03 µm
398855	(941072)	PL-304-10-8	(941073)	3	4-1/16	—		10µm Cell
	(941074) Old	PL-307-10-3	—	3	7-1/8	—		10µm Cell
398856	(941074) New	PL-308-10-9	(941075)	3-1/8	8	—		10µm Cell
922788	—	PL-305-25-10	—	3	4-3/8	—		25µm Cell
922789	—	PL-507-25-10	—	4-5/8	7	—		25µm Cell
936960	—	PL-507-10-3	—	4-1/2	7	—		10µ Cell
941048	(SA404211)	PL-418-10-12	—	4	18	2-1/4		10µ Cell
	(SA404209)	PL-418-10-12	—	4	18	2-1/4		10µ Cell

*FB, FD, FF & FE

PARKER

Replacement elements for Parker Hannifin BULKHEAD FILTERS

Your Model 100-B Bulkhead filter elements are **not** obsolete or 'orphaned'!

We can supply the elements needed to keep them working. We make them to the original manufacturer's specifications, and they will serve every bit as well as those originally supplied. Being flat, they're easy to clean from both sides.

The 600 sq.-in. element surface is of 200-mesh stainless steel wire cloth (74-micron openings) over a perforated steel backing. This is pleated to fit into



a 10x11x2-in. size rectangular shape. The soft rubber-like frame seals effectively against the internal filter supports.

Flows to 100 gpm can be passed, incurring only a .25 psi pressure drop (based on 100 SSU viscosity oil through a clean filter).

Order Flow Ezy Part No.5034-01
Other mesh sizes are available with a minimum order of six units.

PART NUMBER CROSS REFERENCE

Paper & Synthetic Size = 1-21/32" O.D. x 1-7/8" lg. x 11/16" I.D.
Wire Cloth Size = 1-5/8" O.D. x 1-7/8" lg.

ROSAEN PARKER NO.			FLOW EZY NO.	DESCRIPTION
3-S-238W	901463	927267	3195-05	238 μm Wrapped Wire Cloth
3-S-149W	901464	927268	3195-06	149 μm Wrapped Wire Cloth
3-S-74W	901465	927269	3195-07	74 μm Wrapped Wire Cloth
3-S-40W	901466	927270	3195-08	40 μm Wrapped Wire Cloth
3-S-25W	901467	927271	3195-09	25 μm Wrapped Wire Cloth
3-S-40A	923035	—	5640-01	40 μm Pleated Synthetic Fiber
3-S-15A	—	—	5640-02	15 μm Pleated Synthetic Fiber
3-S-40C	—	—	5640-03	40 μm Pleated Cellulose Paper
3-S-20C	901472	—	5640-05	20 μm Pleated Cellulose Paper
3-S-10C	901473	—	5640-06	10 μm Pleated Cellulose Paper
3-S-05C	—	—	5640-07	05 μm Pleated Cellulose Paper
3-S-03C	924500	—	5640-08	03 μm Pleated Cellulose Paper

NOTE: Inner support tube supplied as standard. No extra charge.

ELEMENTS FOR FILTER SERIES:

5-S and 5-F, 225-S and 225-F, 10-S and 10-F, 225-P, 225-IL

Paper & Synthetic Size = 2-3/4" O.D. x 2-1/4" lg. x 1-11/16" I.D.
Wire Cloth Size = 2-15/16" O.D. x 2-1/4" lg.

ROSAEN PARKER NO.			VICKERS NO.	FLOW EZY NO.	DESCRIPTION
5-S-238W	1481	—	938367	1602-05	238 μm Wrapped Wire Cloth
5-S-149W	1485	—	938366	1602-06	149 μm Wrapped Wire Cloth
5-S-74W	1486	—	938365	1602-07	74 μm Wrapped Wire Cloth
5-S-40W	1487	—	—	1602-08	40 μm Wrapped Wire Cloth
5-S-25W	1488	—	—	1602-09	25 μm Wrapped Wire Cloth
5-S-40A	1489	922789	—	5641-01	40 μm Pleated Synthetic Fiber
5-S-15A	1490	—	—	5641-02	15 μm Pleated Synthetic Fiber
5-S-40C	1491	—	—	5641-03	40 μm Pleated Cellulose Paper
5-S-20C	1493	901493	938364	5641-05	20 μm Pleated Cellulose Paper
5-S-10C	1494	901494	—	5641-06	10 μm Pleated Cellulose Paper
5-S-05C	1495	—	—	5641-07	05 μm Pleated Cellulose Paper
5-S-03C	1496	924486	—	5641-08	03 μm Pleated Cellulose Paper
10-S-238W	1505	922931	938370	1603-05	238 μm Pleated Wire Cloth
10-S-149W	1506	922932	938369	1603-06	149 μm Pleated Wire Cloth
10-S-74W	1507	922933	938368	1603-07	74 μm Pleated Wire Cloth
10-S-40W	1508	922934	—	1603-08	40 μm Pleated Wire Cloth
10-S-25W	1509	922935	—	1603-09	25 μm Pleated Wire Cloth

NOTE: Inner support tube supplied as standard. No extra charge.

10-S-238W	—	922936	—	1603-05C	Cart. Assy.
10-S-149W	—	922937	—	1603-06C	Cart. Assy.
10-S-74W	—	922938	—	1603-07C	Cart. Assy.
10-S-40W	—	922939	—	1603-08C	Cart. Assy.
10-S-25W	—	922940	—	1603-09C	Cart. Assy.
5-S-40A	—	922790	—	5641-01C	Cart. Assy.
5-S-20C	—	901173	—	5641-05C	Cart. Assy.
5-S-10C	—	901174	—	5641-06C	Cart. Assy.
5-S-03C	—	924485	—	5641-08C	Cart. Assy.

PART NUMBER CROSS REFERENCE

Paper & Synthetic Size = 2-3/4" O.D. x 6-1/2" lg. x 1-11/16" I.D.

Wire Cloth Size = 2-15/16" O.D. x 6-1/2" lg.

ROSAEN PARKER NO.			VICKERS NO.	FLOW EZY NO.	DESCRIPTION
20-S-238W	1526	—	938373	1604-05	238 μm Wrapped Wire Cloth
20-S-149W	1527	—	938372	1604-06	149 μm Wrapped Wire Cloth
20-S-74W	1528	—	938371	1604-07	74 μm Wrapped Wire Cloth
20-S-40W	1529	—	—	1604-08	40 μm Wrapped Wire Cloth
20-S-25W	1530	—	—	1604-09	25 μm Wrapped Wire Cloth
20-S-40A	1531	922792	—	5642-01	40 μm Pleated Synthetic Fiber
20-S-15A	1532	—	—	5642-02	15 μm Pleated Synthetic Fiber
20-S-40C	1533	—	—	5642-03	40 μm Pleated Cellulose Paper
20-S-20C	1535	901535	938657	5642-05	20 μm Pleated Cellulose Paper
20-S-10C	1536	901536	—	5642-06	10 μm Pleated Cellulose Paper
20-S-05C	1537	—	—	5642-07	05 μm Pleated Cellulose Paper
20-S-03C	1538	924489	—	5642-08	03 μm Pleated Cellulose Paper
50-S-238W	1568	922971	938374	1605-05	238 μm Pleated Wire Cloth
50-S-149W	1569	922972	938565	1605-06	149 μm Pleated Wire Cloth
50-S-74W	1570	922973	938562	1605-07	74 μm Pleated Wire Cloth
50-S-40W	1571	922974	—	1605-08	40 μm Pleated Wire Cloth
50-S-25W	1572	922975	—	1605-09	25 μm Pleated Wire Cloth

NOTE: Inner support tube supplied as standard. No extra charge.

50-S-238W	—	922976	—	1605-05C	Cart. Assy.
50-S-149W	—	922977	—	1605-06C	Cart. Assy.
50-S-74W	—	922978	—	1605-07C	Cart. Assy.
50-S-40W	—	922979	—	1605-08C	Cart. Assy.
50-S-25W	—	922980	—	1605-09C	Cart. Assy.
20-S-40C	—	922793	—	5642-01C	Cart. Assy.
20-S-10C	—	901273	—	5642-05C	Cart. Assy.
20-S-05C	—	901274	—	5642-06C	Cart. Assy.
20-S-03C	—	924488	—	5642-08C	Cart. Assy.

PART NUMBER CROSS REFERENCE

Paper & Synthetic Size = 2-3/4" O.D. x 8-5/8" lg. x 1-11/16" I.D.

Wire Cloth Size = 2-15/16" O.D. x 8-5/8" lg.

ROSAEN PARKER NO.			VICKERS NO.	FLOW EZY NO.	DESCRIPTION		
30-S-238W	1547	—	—	1800-05	238 μm	Wrapped	Wire Cloth
30-S-149W	1548	—	—	1800-06	149 μm	Wrapped	Wire Cloth
30-S-74W	1549	—	—	1800-07	74 μm	Wrapped	Wire Cloth
30-S-40W	1550	—	—	1800-08	40 μm	Wrapped	Wire Cloth
30-S-25W	1551	—	—	1800-09	25 μm	Wrapped	Wire Cloth
60-S-40A	1552	924730	—	5643-01	40 μm	Pleated	Synthetic Fiber
60-S-15A	1553	—	—	5643-02	15 μm	Pleated	Synthetic Fiber
60-S-40C	1554	—	—	5643-03	40 μm	Pleated	Cellulose Paper
60-S-20C	1556	924735	938558	5643-05	20 μm	Pleated	Cellulose Paper
60-S-10C	1557	924734	—	5643-06	10 μm	Pleated	Cellulose Paper
60-S-05C	1558	—	—	5643-07	05 μm	Pleated	Cellulose Paper
60-S-03C	1559	924733	—	5643-08	03 μm	Pleated	Cellulose Paper
60-S-238W	1589	923006	938561	1801-05	238 μm	Pleated	Wire Cloth
60-S-149W	1590	923007	938560	1801-06	149 μm	Pleated	Wire Cloth
60-S-74W	1591	923008	938559	1801-07	74 μm	Pleated	Wire Cloth
60-S-40W	1592	923009	—	1801-08	40 μm	Pleated	Wire Cloth
60-S-25W	1593	923010	—	1801-09	25 μm	Pleated	Wire Cloth

NOTE: Inner support tube supplied as standard. No extra charge.

60-S-238W	—	923011	—	1801-05C	Cart. Assy.		
60-S-149W	—	923012	—	1801-06C	Cart. Assy.		
60-S-74W	—	923013	—	1801-07C	Cart. Assy.		
60-S-40W	—	923014	—	1801-08C	Cart. Assy.		
60-S-25W	—	923015	—	1801-09C	Cart. Assy.		
60-S-40A	—	922671	—	5643-01C	Cart. Assy.		
60-S-15A	—	—	—	5643-02C	Cart. Assy.		
60-S-40C	—	—	—	5643-03C	Cart. Assy.		
60-S-20C	—	901324	—	5643-05C	Cart. Assy.		
60-S-10C	—	901325	—	5643-06C	Cart. Assy.		
60-S-05C	—	—	—	5643-07C	Cart. Assy.		
60-S-03C	—	—	—	5643-08C	Cart. Assy.		

PART NUMBER CROSS REFERENCE

Paper & Synthetic Size = 5-3/4" O.D. x 9" lg. x 4-1/4" I.D.

Wire Cloth Size = 5-1/2" O.D. x 9" lg.

ROSAEN PARKER NO.			VICKERS NO.	FLOW EZY NO.	DESCRIPTION		
75-S-238W	1610	—	938564	4030-05	238 µm	Wrapped	Wire Cloth
75-S-149W	1611	—	938654	4030-06	149 µm	Wrapped	Wire Cloth
75-S-74W	1612	—	938563	4030-07	74 µm	Wrapped	Wire Cloth
75-S-40W	1613	—	—	4030-08	40 µm	Wrapped	Wire Cloth
75-S-25W	1614	—	—	4030-09	25 µm	Wrapped	Wire Cloth
75-S-40A	1615	922661	—	5644-01	40 µm	Pleated	Synthetic Fiber
75-S-15A	1616	—	—	5644-02	15 µm	Pleated	Synthetic Fiber
75-S-40C	1617	—	—	5644-03	40 µm	Pleated	Cellulose Paper
75-S-20C	1619	901619	938569	5644-05	20 µm	Pleated	Cellulose Paper
75-S-10C	1620	901620	—	5644-06	10 µm	Pleated	Cellulose Paper
75-S-05C	1621	—	—	5644-07	05 µm	Pleated	Cellulose Paper
75-S-03C	1622	924496	—	5644-08	03 µm	Pleated	Cellulose Paper
150-S-238W	1745	901745	938572	4028-05	238 µm	Pleated	Wire Cloth
150-S-149W	1746	901746	938571	4028-06	149 µm	Pleated	Wire Cloth
150-S-74W	1747	901747	938570	4028-07	74 µm	Pleated	Wire Cloth
150-S-40W	1748	901748	—	4028-08	40 µm	Pleated	Wire Cloth
150-S-25W	1749	901749	—	4028-09	25 µm	Pleated	Wire Cloth

NOTE: Inner support tube supplied as standard. No extra charge.

ELEMENTS FOR FILTER SERIES:
200-S and 200-F, 8X13-S and 8X13-F

Paper & Synthetic Size = 8" O.D. x 12-3/4" lg. x 6-1/4" I.D.

Wire Cloth Size = 8" O.D. x 12-3/4" lg.

ROSAEN PARKER NO.			VICKERS NO.	FLOW EZY NO.	DESCRIPTION		
200-S-238W	1772	—	938576	4053-05	238 µm	Pleated	Wire Cloth
200-S-149W	1773	901773	938575	4053-06	149 µm	Pleated	Wire Cloth
200-S-74W	1774	901774	938574	4053-07	74 µm	Pleated	Wire Cloth
200-S-40W	1775	—	—	4053-08	40 µm	Pleated	Wire Cloth
200-S-25W	1776	—	—	4053-09	25 µm	Pleated	Wire Cloth
200-S-40A	1699	—	—	5645-01	40 µm	Pleated	Synthetic Fiber
200-S-15A	1700	—	—	5645-02	15 µm	Pleated	Synthetic Fiber
200-S-40C	1701	—	—	5645-03	40 µm	Pleated	Cellulose Paper
200-S-20C	1703	901703	938609	5645-05	20 µm	Pleated	Cellulose Paper
200-S-10C	1704	901704	—	5645-06	10 µm	Pleated	Cellulose Paper
200-S-05C	1705	—	—	5645-07	05 µm	Pleated	Cellulose Paper
200-S-03C	1706	—	—	5645-08	03 µm	Pleated	Cellulose Paper

NOTE: Inner support tube supplied as standard. No extra charge.

PART NUMBER CROSS REFERENCE

Paper & Synthetic Size = 9" O.D. x 13" lg. x 7-1/8" I.D.

Wire Cloth Size = 9-1/4" O.D. x 13" lg.

ROSAEN PARKER NO.	VICKERS NO.	FLOW EZY NO.	DESCRIPTION		
400-S-238W	400-S-238	2825-05	238 μ m	Pleated	Wire Cloth
400-S-149W	400-S-149	2825-06	149 μ m	Pleated	Wire Cloth
400-S-74W	400-S-74	2825-07	74 μ m	Pleated	Wire Cloth
400-S-40W	400-S-40	2825-08	40 μ m	Pleated	Wire Cloth
400-S-25W	400-S-25	2825-09	25 μ m	Pleated	Wire Cloth
400-S-40A	400-S-40A	4889-01	40 μ m	Pleated	Synthetic Fiber
400-S-15A	400-S-15A	4889-02	15 μ m	Pleated	Synthetic Fiber
400-S-40C	400-S-40C	4889-03	40 μ m	Pleated	Cellulose Paper
400-S-20C	400-S-20C	4889-05	20 μ m	Pleated	Cellulose Paper
400-S-10C	400-S-10C	4889-06	10 μ m	Pleated	Cellulose Paper
400-S-05C	400-S-05C	4889-07	05 μ m	Pleated	Cellulose Paper
400-S-03C	400-S-03C	4889-08	03 μ m	Pleated	Cellulose Paper

NOTE: Inner support tube supplied as standard. No extra charge.

ELEMENTS FOR FILTER SERIES:

31-CF and 31-RF; Mobile Models -CF and -RF

Element Dimensions = 2-1/2" O.D. x 9-3/4" lg. x 1-1/2" I.D.

ROSAEN PARKER NO.	PARKER PART NO.		FLOW EZY NO.	DESCRIPTION		
	Buna Seal	Viton Seal				
31-CF-238W	—	—	5691-05	238 μ m	Pleated	Wire Cloth
31-CF-149W	920522	923440	5691-06	149 μ m	Pleated	Wire Cloth
31-CF-74W	920529	923441	5691-07	74 μ m	Pleated	Wire Cloth
31-CF-40W	920523	923443	5691-08	40 μ m	Pleated	Wire Cloth
31-CF-25W	—	—	5691-09	25 μ m	Pleated	Wire Cloth
31-RF-238W	—	—	5691-05	238 μ m	Pleated	Wire Cloth
31-RF-149W	—	—	5691-06	149 μ m	Pleated	Wire Cloth
31-RF-74W	920524	923442	5691-07	74 μ m	Pleated	Wire Cloth
31-RF-40W	920523	923443	5691-08	40 μ m	Pleated	Wire Cloth
31-RF-25W	—	—	5691-09	25 μ m	Pleated	Wire Cloth
31-CF/RF-40A	922783	923434	5658-01	40 μ m	Pleated	Synthetic Fiber
31-CF/RF-15A	—	—	5658-02	15 μ m	Pleated	Synthetic Fiber
31-CF/RF-40C	—	—	5658-04	40 μ m	Pleated	Cellulose Paper
31-CF/RF-20C	920468	923438	5658-05	20 μ m	Pleated	Cellulose Paper
31-CF/RF-10C	920022	923437	5658-06	10 μ m	Pleated	Cellulose Paper
31-CF/RF-03C	924458	924459	5658-07	03 μ m	Pleated	Cellulose Paper

NOTE: Add F3 to end of Flow Ezy number for Viton seals.

PART NUMBER CROSS REFERENCE

Element Dimensions = 2-3/4" O.D. x 8-5/8" lg. x 1-11/16" I.D.

ROSAEN PARKER NO.	PARKER PART NO.				FLOW EZY NO.	DESCRIPTION		
			Buna Seals	Viton Seals				
41, 42-CF-238W	9290	8433	—	—	5398-01	238 μm	Pleated	Wire Cloth
41, 42-CF-149W	9289	8434	924737	925217	5398-02	149 μm	Pleated	Wire Cloth
41, 42-CF-74W	9283	8435	924739	925219	5192-03	74 μm	Pleated	Wire Cloth
41, 42-CF-40W	9287	8436	924740	925220	5398-04	40 μm	Pleated	Wire Cloth
41, 42-CF-25W	9281	8437	—	—	5192-05	25 μm	Pleated	Wire Cloth
41, 42-RF-238W	9290	8438	—	—	5398-01	238 μm	Pleated	Wire Cloth
41, 42-RF-149W	9289	8439	924737	925217	5398-02	149 μm	Pleated	Wire Cloth
41, 42-RF-74W	9288	8440	924738	925218	5398-03	74 μm	Pleated	Wire Cloth
41, 42-RF-40W	9287	8441	924740	925220	5398-04	40 μm	Pleated	Wire Cloth
41, 42-RF-25W	9286	8442	—	—	5398-05	25 μm	Pleated	Wire Cloth
41, 42-CF/RF-40A	8640	—	924730	925210	4613-01	40 μm	Pleated	Synthetic Fiber
41, 42-CF/RF-15A	8639	—	922670	—	4613-02	15 μm	Pleated	Synthetic Fiber
41, 42-CF/RF-40C	8638	—	—	—	4613-04	40 μm	Pleated	Cellulose Paper
41, 42-CF/RF-20C	8637	—	924735	925215	4613-05	20 μm	Pleated	Cellulose Paper
41, 42-CF/RF-10C	8636	—	924734	925214	4613-06	10 μm	Pleated	Cellulose Paper
41, 42-CF/RF-03C	8635	—	924733	925213	4613-07	03 μm	Pleated	Cellulose Paper

NOTE: Add F3 to end of Flow Ezy number for Viton seals.

ELEMENTS FOR FILTER SERIES:

51-CF and 51-RF, 52-CF and 52-RF; Mobile Models 301, 302, 311 & 312, 401, 402, 411 & 412

Element Dimensions = 4-1/4" O.D. x 9-1/2" lg. x 3-1/8" I.D.

ROSAEN PARKER NO.	PARKER PART NO.				FLOW EZY NO.	DESCRIPTION		
			Buna Seals	Viton Seals				
51, 52-CF-238W	9295	8443	909300	—	5405-01	238 μm	Pleated	Wire Cloth
51, 52-CF-149W	9299	8444	909299	923534	5405-02	149 μm	Pleated	Wire Cloth
51, 52-CF-74W	9293	8445	909293	923539	4445-03	74 μm	Pleated	Wire Cloth
51, 52-CF-40W	9292	8446	909279	923535	5405-04	40 μm	Pleated	Wire Cloth
51, 52-CF-25W	9291	8447	909291	923541	4445-05	25 μm	Pleated	Wire Cloth
51, 52-RF-238W	9300	8488	909300	—	5405-01	238 μm	Pleated	Wire Cloth
51, 52-RF-149W	9299	8449	909299	923534	5405-02	149 μm	Pleated	Wire Cloth
51, 52-RF-74W	9298	8450	909298	923540	5405-03	74 μm	Pleated	Wire Cloth
51, 52-RF-40W	9297	8451	909297	923535	5405-04	40 μm	Pleated	Wire Cloth
51, 52-RF-25W	9296	8452	909296	923542	5405-05	25 μm	Pleated	Wire Cloth
51, 52-CF/RF-40A	8646	—	922785	923543	4931-01	40 μm	Pleated	Synthetic Fiber
51, 52-CF/RF-15A	8645C	—	—	—	4931-02	15 μm	Pleated	Synthetic Fiber
51, 52-CF/RF-40C	8644C	—	—	—	4931-04	40 μm	Pleated	Cellulose Paper
51, 52-CF/RF-20C	8643	—	908643	923536	4931-05	20 μm	Pleated	Cellulose Paper
51, 52-CF/RF-10C	8642	—	908642	923537	4931-06	10 μm	Pleated	Cellulose Paper
51, 52-CF/RF-03C	8641	—	924464	924465	4931-07	03 μm	Pleated	Cellulose Paper

PART NUMBER CROSS REFERENCE

Element Dimensions = 5-5/8" O.D. x 12" lg. x 4" I.D.

ROSAEN PARKER NO.	PARKER PART NO.				FLOW EZY NO.	DESCRIPTION		
		Buna Seals	Viton Seals					
71, 72-CF-238W	9305	8453	—	—	5406-01	238 μm	Pleated	Wire Cloth
71, 72-CF-149W	9304	8454	909309	923534	5406-02	149 μm	Pleated	Wire Cloth
71, 72-CF-74W	9303	8455	909303	923539	4515-03	74 μm	Pleated	Wire Cloth
71, 72-CF-40W	9302	8456	909307	923535	5406-04	40 μm	Pleated	Wire Cloth
71, 72-CF-25W	9301	8457	909301	923541	4515-05	25 μm	Pleated	Wire Cloth
71, 72-RF-238W	9310	8458	—	—	5406-01	238 μm	Pleated	Wire Cloth
71, 72-RF-149W	9309	8459	909309	923534	5406-02	149 μm	Pleated	Wire Cloth
71, 72-RF-74W	9308	8460	909308	923540	5406-03	74 μm	Pleated	Wire Cloth
71, 72-RF-40W	9307	8461	909307	923535	5406-04	40 μm	Pleated	Wire Cloth
71, 72-RF-25W	9306	8462	—	923542	5406-05	25 μm	Pleated	Wire Cloth
71, 72-CF/RF-40A	8652	—	922787	923543	4992-01	40 μm	Pleated	Synthetic Fiber
71, 72-CF/RF-15A	8651	—	—	—	4992-02	15 μm	Pleated	Synthetic Fiber
71, 72-CF/RF-40C	8650	—	—	—	4992-04	40 μm	Pleated	Cellulose Paper
71, 72-CF/RF-20C	8649	—	908649	923536	4992-05	20 μm	Pleated	Cellulose Paper
71, 72-CF/RF-10C	8648	—	908648	923537	4992-06	10 μm	Pleated	Cellulose Paper
71, 72-CF/RF-03C	8647	—	924467	924465	4992-07	03 μm	Pleated	Cellulose Paper

NOTE: Add F3 to end of Flow Ezy number for Viton seals.

ELEMENTS FOR FILTER SERIES:

10-T, 33-T, 33-L

10-T Dimensions = 2-9/16" O.D. x 2" lg.

33-T & 33-L Dimensions= 2-15/16" O.D. x 3-1/2" lg.

ROSAEN PARKER NO.	FLOW EZY NO.			DESCRIPTION		
10-T-238W	1229	—	—	2222-05	238 μm	Pleated Wire Cloth
10-T-149W	1230	901230	—	2222-06	149 μm	Pleated Wire Cloth
10-T-74W	1231	901231	—	2222-07	74 μm	Pleated Wire Cloth
10-T-40W	1232	—	—	2222-08	40 μm	Pleated Wire Cloth
10-T-25W	1233	—	—	2222-09	25 μm	Pleated Wire Cloth
10-T-40A	1489	—	—	5689-01	40 μm	Pleated Synthetic Fiber
10-T-15A	1490	—	—	5689-02	15 μm	Pleated Synthetic Fiber
10-T-30C	1492	—	—	5689-04	30 μm	Pleated Cellulose Paper
33-T-238W	1824	—	—	1798-05	238 μm	Pleated Wire Cloth
33-T-149W	1825	901825	—	1798-06	149 μm	Pleated Wire Cloth
33-T-74W	1826	901826	—	1798-07	74 μm	Pleated Wire Cloth
33-T-40W	1827	—	—	1798-08	40 μm	Pleated Wire Cloth
33-T-25W	1828	—	—	1798-09	25 μm	Pleated Wire Cloth
33-T-40A	20349	—	—	5480-01	40 μm	Pleated Synthetic Fiber
33-T-15A	20350	—	—	5480-02	15 μm	Pleated Synthetic Fiber
33-T-30C	20352	—	—	5480-04	30 μm	Pleated Cellulose Paper

NOTE: Inner support tube supplied as standard. No extra charge.

PART NUMBER CROSS REFERENCE

65-T Dimensions = 5" O.D. x 4-5/8" lg. 100-T Dimensions = 4-3/4" O.D. x 4-5/8" lg.
80-T & 80-L Dimensions = 4-3/4" O.D. x 4-5/8" lg. 150-T Dimensions = 4-7/8" O.D. x 7" lg.

ROSAEN PARKER NO.			FLOW EZY NO.	DESCRIPTION
65-T-238W	1374	927104	2429-05	238 μ m Pleated Wire Cloth
65-T-149W	1375	901375, 927105	2429-06	149 μ m Pleated Wire Cloth
65-T-74W	1376	901376, 927106	2429-07	74 μ m Pleated Wire Cloth
65-T-40W	1377	—	2429-08	40 μ m Pleated Wire Cloth
65-T-25W	1378	—	2429-09	25 μ m Pleated Wire Cloth
80-W-238W	1401	927112	2899-05	238 μ m Pleated Wire Cloth
80-W-149W	1402	901402, 927109	2899-06	149 μ m Pleated Wire Cloth
80-T-74W	1403	901403, 927110	2899-07	74 μ m Pleated Wire Cloth
80-T-40W	1404	—	2899-08	40 μ m Pleated Wire Cloth
80-T-25W	1405	—	2899-09	25 μ m Pleated Wire Cloth
100-T-238W	1401	927112	2899-05	238 μ m Pleated Wire Cloth
100-T-149W	1402	927109	2899-06	149 μ m Pleated Wire Cloth
100-T-74W	1403	927110	2899-07	74 μ m Pleated Wire Cloth
100-T-40W	1404	—	2899-08	40 μ m Pleated Wire Cloth
100-T-25W	1405	—	2899-09	25 μ m Pleated Wire Cloth
150-T-238W	1510	—	2818-05	238 μ m Pleated Wire Cloth
150-T-149W	1511	901511, 927119	2818-06	149 μ m Pleated Wire Cloth
150-T-74W	1512	910512, 927114	2818-07	74 μ m Pleated Wire Cloth
150-T-40W	1513	—	2818-08	40 μ m Pleated Wire Cloth
150-T-25W	1514	—	2818-09	25 μ m Pleated Wire Cloth

NOTE: Inner support tube supplied as standard. No extra charge.

ELEMENTS FOR FILTER SERIES:
11-KV Obsolete Pipeless Models

Element Dimensions: 11-KV = 2-1/8" O.D. x 12-1/4" lg.

ROSAEN PARKER NO.	FLOW EZY NO.	DESCRIPTION
11-KV-238W	3785-05	238 μ m Pleated Wire Cloth
11-KV-149W	3785-06	149 μ m Pleated Wire Cloth
11-KV-74W	3785-07	74 μ m Pleated Wire Cloth
11-KV-40W	3785-08	40 μ m Pleated Wire Cloth
11-KV-30W	3785-09	30 μ m Pleated Wire Cloth
11-KV-25D	3643-02	25 μ m Pleated Nylon Cloth
11-KV-40A	—	40 μ m Pleated Synthetic Fiber
11-KV-40C	4993-03	40 μ m Pleated Cellulose Paper
11-KV-30C	—	30 μ m Pleated Cellulose Paper
11-KV-20C	4993-05	20 μ m Pleated Cellulose Paper
11-KV-10C	4993-06	10 μ m Pleated Cellulose Paper
11-KV-05C	4993-07	05 μ m Pleated Cellulose Paper

PART NUMBER CROSS REFERENCE

Element Dimensions = 18-KV = 2-43/64" O.D. x 13-1/2" lg.

ROSAEN PARKER NO.	FLOW EZY NO.	DESCRIPTION
18-KV-238W	3787-05	238 μ m Pleated Wire Cloth
18-KV-149W	3787-06	149 μ m Pleated Wire Cloth
18-KV-74W	3787-07	74 μ m Pleated Wire Cloth
18-KV-40W	3787-08	40 μ m Pleated Wire Cloth
18-KV-30W	3787-09	30 μ m Pleated Wire Cloth
18-KV-25D	3645-02	25 μ m Pleated Nylon Cloth
18-KV-40A	—	40 μ m Pleated Synthetic Fiber
18-KV-40C	—	40 μ m Pleated Cellulose Paper
18-KV-30C	—	30 μ m Pleated Cellulose Paper
18-KV-20C	4844-05	20 μ m Pleated Cellulose Paper
18-KV-10C	—	10 μ m Pleated Cellulose Paper
18-KV-05C	—	05 μ m Pleated Cellulose Paper

**ELEMENTS FOR FILTER SERIES:
36-KV; Obsolete Pipeless Models**

Element Dimensions = 36-KV = 3-1/16" O.D. x 18" lg.

ROSAEN PARKER NO.	FLOW EZY NO.	DESCRIPTION
36-KV-238W	3788-05	238 μ m Pleated Wire Cloth
36-KV-149W	3788-06	149 μ m Pleated Wire Cloth
36-KV-74W	3788-07	74 μ m Pleated Wire Cloth
36-KV-40W	3788-08	40 μ m Pleated Wire Cloth
36-KV-30W	3788-09	30 μ m Pleated Wire Cloth
36-KV-25D	3644-02	25 μ m Pleated Nylon Cloth
36-KV-40A	—	40 μ m Pleated Synthetic Fiber
36-KV-40C	4674-03	40 μ m Pleated Cellulose Paper
36-KV-30C	4674-04	30 μ m Pleated Cellulose Paper
36-KV-20C	4674-05	20 μ m Pleated Cellulose Paper
36-KV-10C	4674-06	10 μ m Pleated Cellulose Paper
36-KV-05C	4674-07	05 μ m Pleated Cellulose Paper

PART NUMBER CROSS REFERENCE

Element Dimensions = 72-KV = 4-1/2" O.D. x 24" lg.

ROSAEN PARKER NO.	FLOW EZY NO.	DESCRIPTION
72-KV-238W	3796-05	238 μ m Pleated Wire Cloth
72-KV-149W	3796-06	149 μ m Pleated Wire Cloth
72-KV-74W	3796-07	74 μ m Pleated Wire Cloth
72-KV-40W	3796-08	40 μ m Pleated Wire Cloth
72-KV-30W	3796-09	30 μ m Pleated Wire Cloth
72-KV-25D	3797-02	25 μ m Pleated Nylon Cloth
72-KV-40A	5064-01	40 μ m Pleated Synthetic Fiber
72-KV-40C	5064-03	40 μ m Pleated Cellulose Paper
72-KV-30C	5064-04	30 μ m Pleated Cellulose Paper
72-KV-20C	5064-05	20 μ m Pleated Cellulose Paper
72-KV-10C	5064-06	10 μ m Pleated Cellulose Paper
72-KV-05C	5064-07	05 μ m Pleated Cellulose Paper

ELEMENTS FOR FILTER SERIES:

20-IL and 20-IH, 350-IL and 350-IH, 375-IL, Binks-85-CA, Binks-85-CB

Paper & Synthetic Size = 2-3/4" O.D. x 3-1/2" lg. x 1-11/16" I.D.

Wire Cloth Size = 2-15/16" O.D. x 3-1/2" lg.

ROSAEN PARKER NO.	FLOW EZY NO.	DESCRIPTION
20-IL, IH-238W 1824 901824, 922991	1798-05	238 μ m Pleated Wire Cloth
20-IL, IH-149W 1825 901825, 922992	1798-06	149 μ m Pleated Wire Cloth
20-IL, IH-74W 1826 901826, 922993	1798-07	74 μ m Pleated Wire Cloth
20-IL, IH-40W 1827 —	1798-08	40 μ m Pleated Wire Cloth
20-IL, IH-25W 1828 —	1798-09	25 μ m Pleated Wire Cloth
20-IL, IH-40A 1852 922955	5646-01	40 μ m Pleated Synthetic Fiber
20-IL, IH-15A 1853 —	5646-02	15 μ m Pleated Synthetic Fiber
20-IL, IH-40C 1854 —	5646-04	40 μ m Pleated Cellulose Paper
20-IL, IH-20C 1856 901856	5646-05	20 μ m Pleated Cellulose Paper
20-IL, IH-10C 1857 901857	5646-06	10 μ m Pleated Cellulose Paper
20-IL, IH-05C 1858 —	5646-07	05 μ m Pleated Cellulose Paper
20-IL, IH-03C 1859 924493	—	03 μ m Pleated Cellulose Paper

NOTE: Inner support tube supplied as standard. No extra charge.

PART NUMBER CROSS REFERENCE

Element Dimensions = 31-P, 33-P and 53-P = 3-3/4" O.D. x 8-3/64" lg.

Element Dimensions = 61-P, 35-P and 55-P = 3-3/4" O.D. x 15-7/16" lg.

ROSAEN PARKER NO.	PARKER PART NO.		FLOW EZY NO.	DESCRIPTION		
31, 33, 53-P-74W	7230	907230	5335-03	74 µm	Pleated	Wire Cloth
31, 33, 53-P-40W	7231	907231	5335-04	40 µm	Pleated	Wire Cloth
31, 33, 53-P-25W	7232	907232	5335-05	25 µm	Pleated	Wire Cloth
31, 33, 53-P-40A	7237	922961	5333-01	40 µm	Pleated	Synthetic Fiber
31, 33, 53-P-15A	7582	—	5333-02	15 µm	Pleated	Synthetic Fiber
31, 33, 53-P-20C	7233	907233	5333-05	20 µm	Pleated	Cellulose Paper
31, 33, 53-P-10C	7234	907234	5333-06	10 µm	Pleated	Cellulose Paper
31, 33, 53-P-03C	7235	924588	5333-07	03 µm	Pleated	Cellulose Paper
61, 35, 55-P-74W	7092	—	5327-03	74 µm	Pleated	Wire Cloth
61, 35, 55-P-40W	7091	907091	5327-04	40 µm	Pleated	Wire Cloth
61, 35, 55-P-25W	7090	907090	5327-05	25 µm	Pleated	Synthetic Fiber
61, 35, 55-P-40A	7086	923056	5028-01	40 µm	Pleated	Synthetic Fiber
61, 35, 55-P-15A	7303	—	5028-02	15 µm	Pleated	Synthetic Fiber
61, 35, 55-P-20C	7089	907089	5028-05	20 µm	Pleated	Cellulose Paper
61, 35, 55-P-10C	7088	907088	5028-06	10 µm	Pleated	Cellulose Paper
61, 35, 55-P-03C	7087	904589	5028-07	03 µm	Pleated	Cellulose Paper

NOTE: Old style nylon end cap only - no O-ring.

ELEMENTS FOR FILTER SERIES:

200-DC, 200-DX, and 200-DD, 300-DC, 300-DX, and 300-DD. Also available for DCW and DXW models

Model 200 - Wire Cloth = 3-7/8" O.D. x 5-1/4" lg.

Paper = 3-13/16" O.D. x 5-1/4" lg.

Model 300 - Wire Cloth = 3-7/8" O.D. x 7-1/2" lg.

Paper = 3-13/16" O.D. x 7-1/2" lg.

ROSAEN PARKER NO.	PARKER PART NO.		FLOW EZY NO.	DESCRIPTION		
200-DC-238W	6448	—	4712-05	238 µm	Pleated	Wire Cloth
200-DC-149W	6449	906449	4712-06	149 µm	Pleated	Wire Cloth
200-DC-74W	6450	906450	4712-07	74 µm	Pleated	Wire Cloth
200-DC-40W	6451	906451	4712-08	40 µm	Pleated	Wire Cloth
200-DC-25W	6452	906452	4712-09	25 µm	Pleated	Wire Cloth
200-DC-40A	8923	923041	4743-01	40 µm	Pleated	Synthetic Fiber
200-DC-15A	8921	—	4743-02	15 µm	Pleated	Synthetic Fiber
200-DC-20C	6264	906264	4743-05	20 µm	Pleated	Cellulose Paper
200-DC-10C	6263	—	4743-06	10 µm	Pleated	Cellulose Paper
300-DC-238W	6453	906453	4743-05	238 µm	Pleated	Wire Cloth
300-DC-149W	6454	906454	4713-06	149 µm	Pleated	Wire Cloth
300-DC-74W	6455	906455	4713-07	74 µm	Pleated	Wire Cloth
300-DC-40W	6456	906456	4713-08	40 µm	Pleated	Wire Cloth
300-DC-25W	6457	906457	4713-09	25 µm	Pleated	Wire Cloth
300-DC-40A	8954	923044	4814-01	40 µm	Pleated	Synthetic Fiber
300-DC-15A	8952	—	4814-02	15 µm	Pleated	Synthetic Fiber
300-DC-20C	6266	—	4814-05	20 µm	Pleated	Cellulose Paper
300-DC-10C	6265	—	4814-06	10 µm	Pleated	Cellulose Paper

PART NUMBER CROSS REFERENCE

Model 400 - Wire Cloth = 3-7/8" O.D. x 13-3/4" lg.
 Model 500 - Wire Cloth = 6-1/16" O.D. x 11" lg.

Paper = 3-13/16" O.D. x 13-3/4" lg.
 Paper = 6-7/32" O.D. x 11" lg.

ROSAEN PARKER NO.	PARKER PART NO.	FLOW EZY NO.	DESCRIPTION
400-DC-238W	6448 —	4714-05	238 μ m Pleated Wire Cloth
400-DC-149W	6459 906459	4714-06	149 μ m Pleated Wire Cloth
400-DC-74W	6460 906460	4714-07	74 μ m Pleated Wire Cloth
400-DC-40W	6461 906461	4714-08	40 μ m Pleated Wire Cloth
400-DC-25W	6462 906462	4714-09	25 μ m Pleated Wire Cloth
400-DC-40A	8981 923047	4842-01	40 μ m Pleated Synthetic Fiber
400-DC-15A	8979 —	4842-02	15 μ m Pleated Synthetic Fiber
400-DC-20C	6268 —	4842-05	20 μ m Pleated Cellulose Paper
400-DC-10C	6267 —	4842-06	10 μ m Pleated Cellulose Paper
500-DC-238W	7786 —	5202-05	238 μ m Pleated Wire Cloth
500-DC-149W	7787 907787	5202-06	149 μ m Pleated Wire Cloth
500-DC-74W	7788 —	5202-07	74 μ m Pleated Wire Cloth
500-DC-40W	7789 —	5202-08	40 μ m Pleated Wire Cloth
500-DC-25W	9016 —	5202	25 μ m Pleated Wire Cloth
500-DC-40A	— 923050	5226-01	40 μ m Pleated Synthetic Fiber
500-DC-15A	8999 —	5226-02	15 μ m Pleated Synthetic Fiber
500-DC-20C	7932 —	5226-05	20 μ m Pleated Cellulose Paper
500-DC-10C	7833 —	5226-06	10 μ m Pleated Cellulose Paper

ELEMENTS FOR FILTER SERIES:

600-DC, 600-DX, and 600-DD, 800-DC, 800-DX, and 800-DD. Also available for DCW and DXW models

Model 600 - Wire Cloth = 6-1/16" O.D. x 17-1/8" lg.
 Model 800 - Wire Cloth = 9" O.D. x 11-3/4" lg.

Paper = 6-7/32" O.D. x 17-1/8" lg.
 Paper = 9-5/32" O.D. x 11-7/8" lg.

ROSAEN PARKER NO.	PARKER PART NO.	FLOW EZY NO.	DESCRIPTION
600-DC-238W	6463 —	4715-02	238 μ m Pleated Wire Cloth
600-DC-149W	6464 906464	4715-03	149 μ m Pleated Wire Cloth
600-DC-74W	6465 906465	4715-04	74 μ m Pleated Wire Cloth
600-DC-40W	6466 906466	—	40 μ m Pleated Wire Cloth
600-DC-25W	8486 903486	4715-06	25 μ m Pleated Wire Cloth
600-DC-40A	6260 923053	4846-01	40 μ m Pleated Synthetic Fiber
600-DC-15A	9007 —	4846-02	15 μ m Pleated Synthetic Fiber
600-DC-20C	9062 —	4846-05	20 μ m Pleated Cellulose Paper
600-DC-10C	9061 —	4846-06	10 μ m Pleated Cellulose Paper
800-DC-238W	9840 (2 req'd) —	5303-05	238 μ m Pleated Wire Cloth
800-DC-149W	9841 (2 req'd) 906454	5303-06	149 μ m Pleated Wire Cloth
800-DC-74W	9842 (2 req'd) —	5303-07	74 μ m Pleated Wire Cloth
800-DC-40W	9843 (2 req'd) —	5303-08	40 μ m Pleated Wire Cloth
800-DC-25W	9844 (2 req'd) —	5303-09	25 μ m Pleated Wire Cloth
800-DC-40A	7685 (2 req'd) —	5246-01	40 μ m Pleated Synthetic Fiber
800-DC-15A	7686 (2 req'd) —	5246-02	15 μ m Pleated Synthetic Fiber
800-DC-20C	7683 (2 req'd) —	5246-05	20 μ m Pleated Cellulose Paper
800-DC-10C	7682 (2 req'd) —	5246-06	10 μ m Pleated Cellulose Paper

PART NUMBER CROSS REFERENCE

15-NS Dimensions = 2-27/32" O.D. x 2-1/16" lg.
 25-NS & 25-NT Dimensions = 2-13/16" O.D. x 2-7/8" lg.

PARKER NO.			RACINE NO.	FLOW EZY NO.	DESCRIPTION		
15-NS-238W	9225	—	15-NS-238W	4639-01	238 μm	Pleated	Wire Cloth
15-NS-149W	9224	909224	15-NS-149W	4639-02	149 μm	Pleated	Wire Cloth
15-NS-74W	9223	909223	15-NS-74W	4639-0	74 μm	Pleated	Wire Cloth
15-NS-40W	9222	—	15-NS-40W	4639-06)	40 μm	Pleated	Wire Cloth
15-NS-25W	9221	—	15-NS-25W	4639-05)	25 μm	Pleated	Wire Cloth
25-NS-238W	7010	907010	25-NS-238W	4280-05	238 μm	Pleated	Wire Cloth
25-NS-149W	7008	907008	25-NS-149W	4280-06	149 μm	Pleated	Wire Cloth
25-NS-74W	3331	903331	25-NS-74W	4280-07	74 μm	Pleated	Wire Cloth
25-NS-40W	7006	907006	25-NS-40W	4280-08	40 μm	Pleated	Wire Cloth
25-NS-25W	8204	—	25-NS-25W	4280-09	25 μm	Pleated	Wire Cloth

**ELEMENTS FOR FILTER SERIES:
45-NS and 45-NT, 135-NS and 135-NT**

45-NS & 45-NT Dimensions = 2-27/32" O.D. x 2-1/16" lg.
 135-NS & 135-NT Dimensions = 2-13/16" O.D. x 2-7/8" lg.

PARKER NO.			RACINE NO.	FLOW EZY NO.	DESCRIPTION		
45-NS-238W	8214	908214	45-NS-238W	4194-01	238 μm	Pleated	Wire Cloth
45-NS-149W	8216	908216	45-NS-149W	4194-02	149 μm	Pleated	Wire Cloth
45-NS-74W	8218	908218	45-NS-74W	4194-03	74 μm	Pleated	Wire Cloth
45-NS-40W	8220	908220	45-NS-40W	4194-06	40 μm	Pleated	Wire Cloth
45-NS-25W	8222	—	45-NS-25W	4194-05	25 μm	Pleated	Wire Cloth
135-NS-238W	6836	906836	135-NS-238W	4299-01	238 μm	Pleated	Wire Cloth
135-NS-149W	6837	906837	135-NS-149W	4299-02	149 μm	Pleated	Wire Cloth
135-NS-74W	6838	906838	135-NS-74W	4299-03	74 μm	Pleated	Wire Cloth
135-NS-40W	6839	906839	135-NS-40W	4299-04	40 μm	Pleated	Wire Cloth
135-NS-25W	6840	—	135-NS-25W	4299-05	25 μm	Pleated	Wire Cloth

**ELEMENTS FOR FILTER SERIES:
205-NS**

205-NS Dimensions = 5-7/16" O.D. x 7-1/4" lg. x 4-1/4 I.D.

PARKER NO.		RACINE NO.	FLOW EZY NO.	DESCRIPTION		
205-NS-238W	6831	205-NS-238W	5106-01	238 μm	Pleated	Wire Cloth
205-NS-149W	6832	205-NS-149W	5106-02	149 μm	Pleated	Wire Cloth
205-NS-74W	6833	205-NS-74W	5106-03	74 μm	Pleated	Wire Cloth
205-NS-40W	6834	205-NS-40W	5106-05	40 μm	Pleated	Wire Cloth
205-NS-25W	6835	205-NS-25W	5106-06	25 μm	Pleated	Wire Cloth

PART NUMBER CROSS REFERENCE

Single Element Dimensions = 3-11/16" O.D. x 9-5/16" lg. x 1-3/4" I.D.
Double Element Dimensions = 3-11/16" O.D. x 18-9/16" lg. x 1-3/4" I.D.

PARKER NO.	FLOW EZY NO.	DESCRIPTION			SEALS BUNA N		
N/A	7605-02	Single Element	5 µm	Cellulose	(2)	11154-01	Grommet
924450	7605-01	Single Element	10 µm	Cellulose	(2)	11154-01	Grommet
924451	7605-00	Single Element	20 µm	Cellulose	(2)	11154-01	Grommet
924454	7605-09	Single Element	25 µm	Wire Cloth	(2)	11154-01	Grommet
924455	7605-08	Single Element	40 µm	Wire Cloth	(2)	11154-01	Grommet
924456	7605-07	Single Element	74 µm	Wire Cloth	(2)	11154-01	Grommet
N/A	7605-06	Single Element	149 µm	Wire Cloth	(2)	11154-01	Grommet
N/A	7605-05	Single Element	238 µm	Wire Cloth	(2)	11154-01	Grommet
N/A	7605-03	Single Element	15A µm	Synthetic	(2)	11154-01	Grommet
924448	7605-04	Single Element	40A µm	Synthetic	(2)	11154-01	Grommet
924453	7605-20	Single Element	10B Glass	Not Beta Rated	(2)	11154-01	Grommet
N/A	7605-02D	Double Element	5 µm	Cellulose	(1)	11154-01	Coupling
924792	7605-01D	Double Element	10 µm	Cellulose	(1)	11154-03	Coupling
924793	7605-00D	Double Element	20 µm	Cellulose	(1)	11154-03	Coupling
924796	7605-09D	Double Element	25 µm	Wire Cloth	(1)	11154-03	Coupling
924797	7605-08D	Double Element	40 µm	Wire Cloth	(1)	11154-03	Coupling
924798	7605-07D	Double Element	74 µm	Wire Cloth	(1)	11154-03	Coupling
N/A	7605-06D	Double Element	149 µm	Wire Cloth	(1)	11154-03	Coupling
N/A	7605-05D	Double Element	238 µm	Wire Cloth	(1)	11154-03	Coupling
N/A	7605-03D	Double Element	15A µm	Synthetic	(1)	11154-03	Coupling
924790	7605--4D	Double Element	40A µm	Synthetic	(1)	11154-03	Coupling
924795	7605-20D	Double Element	10B Glass	Not Beta Rated	(1)	11154-03	Coupling

ELEMENTS FOR FILTER SERIES: CF2, RF2, IL2

Single Element Dimensions = 3-11/16" O.D. x 9-5/16" lg. x 1-3/4" I.D.
Double Element Dimensions = 3-11/16" O.D. x 18-9/16" lg. x 1-3/4" I.D.

PARKER NO.	FLOW EZY NO.	DESCRIPTION			SEALS VITON		
N/A	F3-7605-02	Single Element	5 µm	Cellulose	(2)	11154-02	Grommet
925037	F3-7605-01	Single Element	10 µm	Cellulose	(2)	11154-02	Grommet
925038	F3-7605-00	Single Element	20 µm	Cellulose	(2)	11154-02	Grommet
925041	F3-7605-09	Single Element	25 µm	Wire Cloth	(2)	11154-02	Grommet
925042	F3-7605-08	Single Element	40 µm	Wire Cloth	(2)	11154-02	Grommet
925043	F3-7605-07	Single Element	74 µm	Wire Cloth	(2)	11154-02	Grommet
N/A	F3-7605-06	Single Element	149 µm	Wire Cloth	(2)	11154-02	Grommet
N/A	F3-7605-05	Single Element	238 µm	Wire Cloth	(2)	11154-02	Grommet
N/A	F3-7605-03	Single Element	15A µm	Synthetic	(2)	11154-02	Grommet
925035	F3-7605-04	Single Element	40A µm	Synthetic	(2)	11154-02	Grommet
925040	F3-7605-20	Single Element	10B Glass	Not Beta Rated	(2)	11154-02	Grommet
N/A	F3-7605-02D	Double Element	5 µm	Cellulose	(1)	11154-02	Coupling
925047	F3-7605-01D	Double Element	10 µm	Cellulose	(1)	11154-04	Coupling
925048	F3-7605-00D	Double Element	20 µm	Cellulose	(1)	11154-04	Coupling
925051	F3-7605-09D	Double Element	25 µm	Wire Cloth	(1)	11154-04	Coupling
925052	F3-7605-08D	Double Element	40 µm	Wire Cloth	(1)	11154-04	Coupling
925053	F3-7605-07D	Double Element	74 µm	Wire Cloth	(1)	11154-04	Coupling
N/A	F3-7605-06D	Double Element	149 µm	Wire Cloth	(1)	11154-04	Coupling
N/A	F3-7605-05D	Double Element	238 µm	Wire Cloth	(1)	11154-04	Coupling
N/A	F3-7605-03D	Double Element	15A µm	Synthetic	(1)	11154-04	Coupling
925045	F3-7605-04D	Double Element	40A µm	Synthetic	(1)	11154-04	Coupling
925050	F3-7605-20D	Double Element	10B Glass	Not Beta Rated	(1)	11154-04	Coupling

PART NUMBER CROSS REFERENCE

Single Element Dimensions = 3-11/16" O.D. x 9-5/16" lg. x 1-3/4" I.D.
 Double Element Dimensions = 3-11/16" O.D. x 18-9/16" lg. x 1-3/4" I.D.

PARKER NO. (OLD)	FLOW EZY NO.	DESCRIPTION			SEALS VITON		
N/A	F3-7605-12	Single Element	5 µm	Cellulose	(2)	11154-01	Grommet
925782	F3-7605-11	Single Element	10 µm	Cellulose	(2)	11154-01	Grommet
925783	F3-7605-10	Single Element	20 µm	Cellulose	(2)	11154-01	Grommet
925784	F3-7605-19	Single Element	25 µm	Wire Cloth	(2)	11154-01	Grommet
925785	F3-7605-18	Single Element	40 µm	Wire Cloth	(2)	11154-01	Grommet
N/A	F3-7605-17	Single Element	74 µm	Wire Cloth	(2)	11154-01	Grommet
N/A	F3-7605-16	Single Element	149 µm	Wire Cloth	(2)	11154-01	Grommet
N/A	F3-7605-15	Single Element	238 µm	Wire Cloth	(2)	11154-01	Grommet
N/A	F3-7605-13	Single Element	15A µm	Synthetic	(2)	11154-01	Grommet
925780	F3-7605-14	Single Element	40A µm	Synthetic	(2)	11154-01	Grommet
N/A	F3-7605-12D	Double Element	5 µm	Cellulose	(1)	11154-01	Coupling
925802	F3-7605-11D	Double Element	10 µm	Cellulose	(1)	11154-03	Coupling
925803	F3-7605-10D	Double Element	20 µm	Cellulose	(1)	11154-03	Coupling
925804	F3-7605-19D	Double Element	25 µm	Wire Cloth	(1)	11154-03	Coupling
925805	F3-7605-18D	Double Element	40 µm	Wire Cloth	(1)	11154-03	Coupling
N/A	F3-7605-17D	Double Element	74 µm	Wire Cloth	(1)	11154-03	Coupling
N/A	F3-7605-16D	Double Element	149 µm	Wire Cloth	(1)	11154-03	Coupling
N/A	F3-7605-15D	Double Element	238 µm	Wire Cloth	(1)	11154-03	Coupling
N/A	F3-7605-13D	Double Element	15A µm	Synthetic	(1)	11154-03	Coupling
925800	F3-7605-14D	Double Element	40A µm	Synthetic	(1)	11154-03	Coupling

Single Element Dimensions = 3-11/16" O.D. x 9-5/16" lg. x 1-3/4" I.D.
 Double Element Dimensions = 3-11/16" O.D. x 18-9/16" lg. x 1-3/4" I.D.

PARKER NO. (NEW)	FLOW EZY NO.	DESCRIPTION			SEALS VITON		
N/A	F3-7605-12	Single Element	5 µm	Cellulose	(2)	11154-01	Grommet
925520	F3-7605-11	Single Element	10 µm	Cellulose	(2)	11154-01	Grommet
925773	F3-7605-10	Single Element	20 µm	Cellulose	(2)	11154-01	Grommet
925774	F3-7605-19	Single Element	25 µm	Wire Cloth	(2)	11154-01	Grommet
925775	F3-7605-18	Single Element	40 µm	Wire Cloth	(2)	11154-01	Grommet
N/A	F3-7605-17	Single Element	74 µm	Wire Cloth	(2)	11154-01	Grommet
N/A	F3-7605-16	Single Element	149 µm	Wire Cloth	(2)	11154-01	Grommet
N/A	F3-7605-15	Single Element	238 µm	Wire Cloth	(2)	11154-01	Grommet
N/A	F3-7605-13	Single Element	15A µm	Synthetic	(2)	11154-01	Grommet
925771	F3-7605-14	Single Element	40A µm	Synthetic	(2)	11154-01	Grommet
N/A	F3-7605-12D	Double Element	5 µm	Cellulose	(1)	11154-01	Coupling
925792	F3-7605-11D	Double Element	10 µm	Cellulose	(1)	11154-03	Coupling
925793	F3-7605-10D	Double Element	20 µm	Cellulose	(1)	11154-03	Coupling
925794	F3-7605-19D	Double Element	25 µm	Wire Cloth	(1)	11154-03	Coupling
925795	F3-7605-18D	Double Element	40 µm	Wire Cloth	(1)	11154-03	Coupling
N/A	F3-7605-17D	Double Element	74 µm	Wire Cloth	(1)	11154-03	Coupling
N/A	F3-7605-16D	Double Element	149 µm	Wire Cloth	(1)	11154-03	Coupling
N/A	F3-7605-15D	Double Element	238 µm	Wire Cloth	(1)	11154-03	Coupling
N/A	F3-7605-13D	Double Element	15A µm	Synthetic	(1)	11154-03	Coupling
925790	F3-7605-14D	Double Element	40A µm	Synthetic	(1)	11154-03	Coupling

PART NUMBER CROSS REFERENCE

Single Element Dimensions = 3-11/16" O.D. x 9-5/16" lg. x 1-3/4" I.D.
 Double Element Dimensions = 3-11/16" O.D. x 18-9/16" lg. x 1-3/4" I.D.

PARKER NO.	FLOW EZY NO.	DESCRIPTION			SEALS BUNA N		
N/A	7605-12	Single Element	5 μ m	Cellulose	(2)	11154-01	Grommet
925520	7605-11	Single Element	10 μ m	Cellulose	(2)	11154-01	Grommet
925773	7605-10	Single Element	20 μ m	Cellulose	(2)	11154-01	Grommet
925774	7605-19	Single Element	25 μ m	Wire Cloth	(2)	11154-01	Grommet
925775	7605-18	Single Element	40 μ m	Wire Cloth	(2)	11154-01	Grommet
N/A	7605-17	Single Element	74 μ m	Wire Cloth	(2)	11154-01	Grommet
N/A	7605-16	Single Element	148 μ m	Wire Cloth	(2)	11154-01	Grommet
N/A	7605-15	Single Element	238 μ m	Synthetic	(2)	11154-01	Grommet
925771	7605-13	Single Element	40A μ m	Synthetic	(2)	11154-01	Grommet
N/A	7605-14	Single Element	15A μ m	Synthetic	(2)	11154-01	Grommet
925790	7605-12D	Double Element	40A μ m	Synthetic	(1)	11154-01	Coupling
925792	7605-11D	Double Element	5 μ m	Cellulose	(1)	11154-03	Coupling
925793	7605-10D	Double Element	10 μ m	Cellulose	(1)	11154-03	Coupling
925794	7605-19D	Double Element	20 μ m	Cellulose	(1)	11154-03	Coupling
925795	7605-18D	Double Element	25 μ m	Wire Cloth	(1)	11154-03	Coupling
N/A	7605-17D	Double Element	40 μ m	Wire Cloth	(1)	11154-03	Coupling
N/A	7605-16D	Double Element	74 μ m	Wire Cloth	(1)	11154-03	Coupling
N/A	7605-15D	Double Element	149 μ m	Wire Cloth	(1)	11154-03	Coupling
N/A	7605-13D	Double Element	238 μ m	Wire Cloth	(1)	11154-03	Coupling
N/A	7605-14D	Double Element	15A μ m	Synthetic	(1)	11154-03	Coupling

PARKER SPIN-ON FILTER

ELEMENTS FOR FILTER SERIES:
12AT, 50AT

PART NUMBER CROSS REFERENCE

FEE 30 (12 AT) Dimensions = 3-11/16" O.D. x 5-1/4" lg. x 1" - 12 I.D.
 FEE 51 (50 AT) Dimensions = 5-3/64" O.D. x 6-7/8" lg. x 1-1/2" - 12 I.D.

PARKER NO.	FLOW EZY NO.	DESCRIPTION			MODEL
926543	FEE-30-03	03 μ m	Cellulose		12AT
921999	FEE-30-10	10 μ m	Cellulose		12AT
9255023	FEE-30-25	25 μ m	Cellulose		12AT
928763	N/A	10B	Micro Glass		12AT
928764	N/A	20B	Micro Glass		12AT
926541	FEE-51-03	03 μ m	Cellulose		50AT
926169	FEE-51-10	10 μ m	Cellulose		50AT
926170	FEE-51-25	25 μ m	Cellulose		50AT
927736	FEE-51-10 (double)	10 μ m	Cellulose		50AT
929445	N/A	10B	Micro Glass		50AT
929446	N/A	20B	Micro Glass		50AT
922073	N/A	03B	Micro Glass		50AT

PART NUMBER CROSS REFERENCE

Paper Dimensions = 3" O.D. x 5" lg. x 1-1/16" I.D.

Wire Cloth Dimensions = 2-7/8" O.D. x 5" lg. x 1-1/16" I.D.

SCHROEDER NO.		FLOW EZY NO.		DESCRIPTION			
* A3	TF Series	7564-08	6581-08	3 μm	Buna	Seals	Paper
* A5	TF Series	7564-07	6581-07	5 μm	Buna	Seals	Paper
* A10	TF Series	7564-06	6581-06	10 μm	Buna	Seals	Paper
* A25	TF Series	7564-05	6581-05	25 μm	Buna	Seals	Paper
* AH3	TF Series	7564-12	6581-12	3 μm	EPR	Seals -epoxy bonded	Paper
* AH5	TF Series	7564-11	6581-11	5 μm	EPR	Seals -epoxy bonded	Paper
* AH10	TF Series	7564-10	6581-10	10 μm	EPR	Seals -epoxy bonded	Paper
* AH25	TF Series	7564-09	6581-09	25 μm	EPR	Seals -epoxy bonded	Paper
AM10	TF Series	7564-04	6581-04	10 μm	Buna	Seals	Wire Cloth
AM25	TF Series	7564-03	6581-03	25 μm	Buna	Seals	Wire Cloth
AM60	TF Series	7564-02	6581-02	60 μm	Buna	Seals	Wire Cloth
AM150	TF Series	7564-01	6581-01	150 μm	Buna	Seals	Wire Cloth
AM260	TF Series	7564-18	6581-18	260 μm	Buna	Seals	Wire Cloth
AHM10	TF Series	7564-17	6581-17	10 μm	EPR	Seals	Wire Cloth
AHM25	TF Series	7564-16	6581-16	25 μm	EPR	Seals	Wire Cloth
AHM60	TF Series	7564-15	6581-15	60 μm	EPR	Seals	Wire Cloth
AHM150	TF Series	7564-14	6581-14	150 μm	EPR	Seals	Wire Cloth
AHM260	TF Series	7564-13	6581-13	260 μm	EPR	Seals	Wire Cloth

* Packaged 12 per carton

BB SERIES

Paper Dimensions = 5" O.D. x 18-5/16" lg. x 3-1/2" I.D.

SCHROEDER NO.		FLOW EZY NO.		DESCRIPTION			
* BB3	BFT Series	10428-08		3 μm	Buna	Seals	Paper
* BB5	BFT Series	10428-07		5 μm	Buna	Seals	Paper
* BB10	BFT Series	10428-06		10 μm	Buna	Seals	Paper
* BB25	BFT Series	10428-05		25 μm	Buna	Seals	Paper
* BBH3	BFT Series	10428-12		3 μm	EPR	Seals -epoxy bonded	Paper
* BBH5	BFT Series	10428-11		5 μm	EPR	Seals -epoxy bonded	Paper
* BBH10	BFT Series	10428-10		10 μm	EPR	Seals -epoxy bonded	Paper
* BBH25	BFT Series	10428-09		25 μm	EPR	Seals -epoxy bonded	Paper

* Packaged 12 per carton

PART NUMBER CROSS REFERENCE

Paper Dimensions = 3" O.D. x 4-3/4" lg. x 1-1/32" I.D.

Wire Cloth Dimensions = 2-1/2" O.D. x 4-7/8" lg. x 1-1/32" I.D.

SCHROEDER NO.	FLOW EZY NO.	DESCRIPTION
* C3 DF30, CF30 Series	10426-08	3 μ m Buna Seals Paper
* C5 DF30, CF30 Series	10426-07	5 μ m Buna Seals Paper
* C10 DF30, CF30 Series	10426-06	10 μ m Buna Seals Paper
* C25 DF30, CF30 Series	10426-05	25 μ m Buna Seals Paper
* CH3 DF30, CF30 Series	10426-12	3 μ m EPR Seals -epoxy bonded Paper
* CH5 DF30, CF30 Series	10426-11	5 μ m EPR Seals -epoxy bonded Paper
* CH10 DF30, CF30 Series	10426-10	10 μ m EPR Seals -epoxy bonded Paper
* CH25 DF30, CF30 Series	10426-09	25 μ m EPR Seals -epoxy bonded Paper
CM10 DF30, CF30 Series	10426-04	10 μ m Buna Seals Wire Cloth
CM25 DF30, CF30 Series	10426-03	25 μ m Buna Seals Wire Cloth
CM60 DF30, CF30 Series	10426-02	60 μ m Buna Seals Wire Cloth
CM150 DF30, CF30 Series	10426-01	150 μ m Buna Seals Wire Cloth
CM260 DF30, CF30 Series	10426-	260 μ m Buna Seals Wire Cloth
CHM10 DF30, CF30 Series	10426-17	10 μ m EPR Seals Wire Cloth
CHM25 DF30, CF30 Series	10426-16	25 μ m EPR Seals Wire Cloth
CHM60 DF30, CF30 Series	10426-15	60 μ m EPR Seals Wire Cloth
CHM150 DF30, CF30 Series	10426-14	150 μ m EPR Seals Wire Cloth
CHM260 DF30, CF30 Series	10426-13	260 μ m EPR Seals Wire Cloth

* Packaged 12 per carton

CC SERIES

Paper Dimensions = 3" O.D. x 9-3/4" lg. x 1-1/32" I.D.

Wire Cloth Dimensions = 2-1/2" O.D. x 9-3/4" lg. x 1-1/32" I.D.

SCHROEDER NO.	FLOW EZY NO.	DESCRIPTION
* CC3 DF30, CF30, CFX Series	10427-08	3 μ m Buna Seals Paper
* CC5 DF30, CF30, CFX Series	10427-07	5 μ m Buna Seals Paper
* CC10 DF30, CF30, CFX Series	10427-06	10 μ m Buna Seals Paper
* CC25 DF30, CF30, CFX Series	10427-05	25 μ m Buna Seals Paper
* CCH3 DF30, CF30, CFX Series	10427-12	3 μ m EPR Seals -epoxy bonded Paper
* CCH5 DF30, CF30, CFX Series	10427-11	5 μ m EPR Seals -epoxy bonded Paper
* CCH10 DF30, CF30, CFX Series	10427-10	10 μ m EPR Seals -epoxy bonded Paper
* CCH25 DF30, CF30, CFX Series	10427-09	25 μ m EPR Seals -epoxy bonded Paper
CCM10 DF30, CF30, CFX Series	10427-04	10 μ m Buna Seals Wire Cloth
CCM25 DF30, CF30, CFX Series	10427-03	25 μ m Buna Seals Wire Cloth
CCM60 DF30, CF30, CFX Series	10427-02	60 μ m Buna Seals Wire Cloth
CCM150 DF30, CF30, CFX Series	10427-01	150 μ m Buna Seals Wire Cloth
CCM260 DF30, CF30, CFX Series	10427-	260 μ m Buna Seals Wire Cloth
CCHM10 DF30, CF30, CFX Series	10427-17	10 μ m EPR Seals Wire Cloth
CCHM25 DF30, CF30, CFX Series	10427-16	25 μ m EPR Seals Wire Cloth
CCHM60 DF30, CF30, CFX Series	10427-15	60 μ m EPR Seals Wire Cloth
CCHM150 DF30, CF30, CFX Series	10427-14	150 μ m EPR Seals Wire Cloth
CCHM260 DF30, CF30, CFX Series	10427-13	260 μ m EPR Seals Wire Cloth

* Packaged 12 per carton

PART NUMBER CROSS REFERENCE

Paper Dimensions = 2-1/2" O.D. x 4-7/8" lg. x 1" I.D.

Wire Cloth Dimensions = 2-1/2" O.D. x 4-7/8" lg. x 1" I.D.

SCHROEDER NO.		FLOW EZY NO.		DESCRIPTION		
* D3	DF30, IFS Series	7563-08	6582-08	3 μ m	Buna Seals	Paper
* D5	DF30, IFS Series	7563-07	6582-07	5 μ m	Buna Seals	Paper
* D10	DF30, IFS Series	7563-06	6582-06	10 μ m	Buna Seals	Paper
* D25	DF30, IFS Series	7563-05	6582-05	25 μ m	Buna Seals	Paper
* DH3	DF30, IFS Series	7563-12	6582-12	3 μ m	EPR Seals -epoxy bonded	Paper
* DH5	DF30, IFS Series	7563-11	6582-11	5 μ m	EPR Seals -epoxy bonded	Paper
* DH10	DF30, IFS Series	7563-10	6582-10	10 μ m	EPR Seals -epoxy bonded	Paper
* DH25	DF30, IFS Series	7563-09	6582-09	25 μ m	EPR Seals -epoxy bonded	Paper
DM10	DF30, IFS Series	7563-04	6582-04	10 μ m	Buna Seals	Wire Cloth
DM25	DF30, IFS Series	7563-03	6582-03	25 μ m	Buna Seals	Wire Cloth
DM60	DF30, IFS Series	7563-02	6582-02	60 μ m	Buna Seals	Wire Cloth
DM150	DF30, IFS Series	7563-01	6582-01	150 μ m	Buna Seals	Wire Cloth
DM260	DF30, IFS Series	7563-18	6582-18	260 μ m	Buna Seals	Wire Cloth
DHM10	DF30, IFS Series	7563-17	6582-17	10 μ m	EPR Seals	Wire Cloth
DHM25	DF30, IFS Series	7563-16	6582-16	25 μ m	EPR Seals	Wire Cloth
DHM60	DF30, IFS Series	7563-15	6582-15	60 μ m	EPR Seals	Wire Cloth
DHM150	DF30, IFS Series	7563-14	6582-14	150 μ m	EPR Seals	Wire Cloth
DHM260	DF30, IFS Series	7563-13	6582-13	260 μ m	EPR Seals	Wire Cloth

* Packaged 12 per carton

DD SERIES

Paper Dimensions = 2-1/2" O.D. x 9-3/4" lg. x 1" I.D.

Wire Cloth Dimensions = 2-1/2" O.D. x 9-3/4" lg. x 1" I.D.

SCHROEDER NO.		FLOW EZY NO.		DESCRIPTION		
* DD3	DF30, IFS Series	PL310-3-17		3 μ m	Buna Seals	Paper
* DD5	DF30, IFS Series	PL310-5-17		5 μ m	Buna Seals	Paper
* DD10	DF30, IFS Series	PL310-10-17		10 μ m	Buna Seals	Paper
* DD25	DF30, IFS Series	PL310-25-17		25 μ m	Buna Seals	Paper
* DDH3	DF30, IFS Series	PL310-3-17A		3 μ m	EPR Seals -epoxy bonded	Paper
* DDH5	DF30, IFS Series	PL310-5-17A		5 μ m	EPR Seals -epoxy bonded	Paper
* DDH10	DF30, IFS Series	PL310-10-17A		10 μ m	EPR Seals -epoxy bonded	Paper
* DDH25	DF30, IFS Series	PL310-25-17A		25 μ m	EPR Seals -epoxy bonded	Paper
DDM10	DF30, IFS Series	10427-04		10 μ m	Buna Seals	Wire Cloth
DDM25	DF30, IFS Series	10427-03		25 μ m	Buna Seals	Wire Cloth
DDM60	DF30, IFS Series	10427-02		60 μ m	Buna Seals	Wire Cloth
DDM150	DF30, IFS Series	10427-01		150 μ m	Buna Seals	Wire Cloth
DDM260	DF30, IFS Series	10427		260 μ m	Buna Seals	Wire Cloth
DDHM10	DF30, IFS Series	10427-17		10 μ m	EPR Seals	Wire Cloth
DDHM25	DF30, IFS Series	10427-16		25 μ m	EPR Seals	Wire Cloth
DDHM60	DF30, IFS Series	10427-15		60 μ m	EPR Seals	Wire Cloth
DDHM150	DF30, IFS Series	10427-14		150 μ m	EPR Seals	Wire Cloth
DDHM260	DF30, IFS Series	10427-13		260 μ m	EPR Seals	Wire Cloth

* Packaged 12 per carton

PART NUMBER CROSS REFERENCE

Paper Dimensions = 3-1/2" O.D. x 9-1/4" lg. x 1-5/8" I.D.

Wire Cloth Dimensions = 3-1/2" O.D. x 9-1/4" lg. x 1-5/8" I.D.

SCHROEDER NO.		FLOW EZY NO.		DESCRIPTION			
* J3	JF20, LF, KF, RT, ST Series**	10407-08	—	3 μm	Buna Seals	Paper	
* J5	JF20, LF, KF, RT, ST Series**	10407-07	—	5 μm	Buna Seals	Paper	
* J10	JF20, LF, KF, RT, ST Series**	10407-06	—	10 μm	Buna Seals	Paper	
* J25	JF20, LF, KF, RT, ST Series**	10407-05	—	25 μm	Buna Seals	Paper	
* JH3	JF20, LF, KF, RT, ST Series**	10407-12	—	3 μm	EPR Seals	-epoxy bonded	Paper
* JH5	JF20, LF, KF, RT, ST Series**	10407-11	—	5 μm	EPR Seals	-epoxy bonded	Paper
* JH10	JF20, LF, KF, RT, ST Series**	10407-10	—	10 μm	EPR Seals	-epoxy bonded	Paper
* JH25	JF20, LF, KF, RT, ST Series**	10407-09	—	25 μm	EPR Seals	-epoxy bonded	Paper
† JM10	JF20, LF, KF, RT, ST Series**	7565-04	40407-04	10 μm	Buna Seals		Wire Cloth
JM25	JF20, LF, KF, RT, ST Series**	7565-03	6583-03	25 μm	Buna Seals		Wire Cloth
JM60	JF20, LF, KF, RT, ST Series**	7565-02	6583-02	60 μm	Buna Seals		Wire Cloth
JM150	JF20, LF, KF, RT, ST Series**	7565-01	6583-01	150 μm	Buna Seals		Wire Cloth
JM260	JF20, LF, KF, RT, ST Series**	7565	6583	260 μm	Buna Seals		Wire Cloth
JHM10	JF20, LF, KF, RT, ST Series**	7565-17	6583-17	10 μm	EPR Seals		Wire Cloth
JHM25	JF20, LF, KF, RT, ST Series**	7565-16	6583-16	25 μm	EPR Seals		Wire Cloth
JHM60	JF20, LF, KF, RT, ST Series**	7565-15	6583-15	60 μm	EPR Seals		Wire Cloth
JHM150	JF20, LF, KF, RT, ST Series**	7565-14	6583-14	150 μm	EPR Seals		Wire Cloth
JHM260	JF20, LF, KF, RT, ST Series**	7565-13	6583-13	260 μm	EPR Seals		Wire Cloth

* Packaged 12 per carton

** LF & KF, RT & ST Series normally use K size elements but can use J size to simplify element inventories.

† KM reusable elements are identical to JM elements.

K SERIES

Paper Dimensions = 3-7/8" O.D. x 9-1/4" lg. x 1-5/8" I.D.

Wire Cloth Dimensions = 3-1/2" O.D. x 9-1/4" lg. x 1-5/8" I.D.

SCHROEDER NO.		FLOW EZY NO.		DESCRIPTION			
* K3	LF, KF, RT, ST Series	7565-08	6583-08	3 μm	Buna Seals	Paper	
* K5	LF, KF, RT, ST Series	7565-07	6583-07	5 μm	Buna Seals	Paper	
* K10	LF, KF, RT, ST Series	7565-06	6583-06	10 μm	Buna Seals	Paper	
* K25	LF, KF, RT, ST Series	7565-05	6583-05	25 μm	Buna Seals	Paper	
* KH3	LF, KF, RT, ST Series	7565-12	6583-12	3 μm	EPR Seals	-epoxy bonded	Paper
* KH5	LF, KF, RT, ST Series	7565-11	6583-11	5 μm	EPR Seals	-epoxy bonded	Paper
* KH10	LF, KF, RT, ST Series	7565-10	6583-10	10 μm	EPR Seals	-epoxy bonded	Paper
* KH25	LF, KF, RT, ST Series	7565-09	6583-09	25 μm	EPR Seals	-epoxy bonded	Paper
† KM10	LF, KF, RT, ST Series	7565-04	6583-04	10 μm	Buna Seals		Wire Cloth
KM25	LF, KF, RT, ST Series	7565-03	6583-03	25 μm	Buna Seals		Wire Cloth
KM60	LF, KF, RT, ST Series	7565-02	6583-02	60 μm	Buna Seals		Wire Cloth
KM150	LF, KF, RT, ST Series	7565-01	6583-01	150 μm	Buna Seals		Wire Cloth
KM260	LF, KF, RT, ST Series	7565	6583	260 μm	Buna Seals		Wire Cloth
KHM10	LF, KF, RT, ST Series	7565-17	6583-17	10 μm	EPR Seals		Wire Cloth
KHM25	LF, KF, RT, ST Series	7565-16	6583-16	25 μm	EPR Seals		Wire Cloth
KHM60	LF, KF, RT, ST Series	7565-15	6583-15	60 μm	EPR Seals		Wire Cloth
KHM150	LF, KF, RT, ST Series	7565-14	6583-14	150 μm	EPR Seals		Wire Cloth
KHM260	LF, KF, RT, ST Series	7565-13	6583-13	260 μm	EPR Seals		Wire Cloth

* Packaged 12 per carton

† KM reusable elements are identical to JM elements.

PART NUMBER CROSS REFERENCE

Mesh, Wire Cloth, Paper Dimensions (closed bottom)

= 2-5/8" O.D. x 4-3/4" lg. x 1-1/4" I.D.

MARVEL NO.	FLOW EZY NO.	DESCRIPTION
529206-1120	6108-03	74 μ m 200 Mesh
529206-1115	6108-07	100 μ m 150 Mesh
529206-1110	6108-02	150 μ m 100 Mesh
529206-1108	6108-08	190 μ m 80 Mesh
529206-1106	6108-01	230 μ m 60 Mesh
529206-1105	6108-09	280 μ m 50 Mesh
529206-1104	6108-10	370 μ m 40 Mesh
529206-1103	6108-11	540 μ m 30 Mesh
529206-2210	6108-05	10 μ m — Wire Cloth
529206-2215	6108-06	15 μ m — Wire Cloth
529206-2225	6108-04	25 μ m — Wire Cloth
529206-2240	6108-12	40 μ m — Wire Cloth
529206-5101	6108-13	1 μ m — Cellulose Paper
529206-5105	6108-14	5 μ m — Cellulose Paper
529206-5110	6108-15	10 μ m — Cellulose Paper
529206-5125	6108-16	25 μ m — Cellulose Paper
529206-5140	6108-17	40 μ m — Cellulose Paper

Mesh, Wire Cloth, Paper Dimensions (closed bottom)

= 2-5/8" O.D. x 4-3/4" lg. x 1-1/4" I.D.

MARVEL NO.	FLOW EZY NO.	DESCRIPTION
530206-1120	F3-6108-03	74 μ m 200 Mesh -epoxy & viton
530206-1115	F3-6108-07	100 μ m 150 Mesh -epoxy & viton
530206-1110	F3-6108-02	150 μ m 100 Mesh -epoxy & viton
530206-1108	F3-6108-08	190 m 80 Mesh -epoxy & viton
530206-1106	F3-6108-01	230 μ m 60 Mesh -epoxy & viton
530206-1105	F3-6108-09	280 μ m 50 Mesh -epoxy & viton
530206-1104	F3-6108-10	370 μ m 40 Mesh -epoxy & viton
530206-1103	F3-6108-11	540 μ m 30 Mesh -epoxy & viton
530206-2210	F3-6108-05	10 μ m — Wire Cloth -epoxy & viton
530206-2215	F3-6108-06	15 μ m — Wire Cloth -epoxy & viton
530206-2225	F3-6108-04	25 μ m — Wire Cloth -epoxy & viton
530206-2240	F3-6108-12	40 μ m — Wire Cloth -epoxy & viton
530206-5101	F3-6108-13	1 μ m — Cellulose Paper -epoxy & viton
530206-5105	F3-6108-14	5 μ m — Cellulose Paper -epoxy & viton
530206-5110	F3-6108-15	10 μ m — Cellulose Paper -epoxy & viton
530206-5125	F3-6108-16	25 μ m — Cellulose Paper -epoxy & viton
530206-5140	F3-6108-17	40 μ m — Cellulose Paper -epoxy & viton

PART NUMBER CROSS REFERENCE

Mesh, Wire Cloth, Paper Dimensions = 2-5/8" O.D. x 7-1/4" lg. x 1-1/4" I.D.

MARVEL NO.	FLOW EZY NO.	DESCRIPTION		
560206-1120	6265-03	74 μm	200	Mesh
560206-1115	6265-07	100 μm	150	Mesh
560206-1110	6265-02	150 μm	100	Mesh
560206-1108	6265-08	190 μm	80	Mesh
560206-1106	6265-01	230 μm	60	Mesh
560206-1105	6265-09	280 μm	50	Mesh
560206-1104	6265-10	370 μm	40	Mesh
560206-1103	6265-11	540 μm	30	Mesh
560206-2210	6265-05	10 μm	—	Wire Cloth
560206-2215	6265-06	15 μm	—	Wire Cloth
560206-2225	6265-04	25 μm	—	Wire Cloth
560206-2240	6265-12	40 μm	—	Wire Cloth
560206-5101	6265-13	1 μm	—	Cellulose Paper
560206-5105	6265-14	5 μm	—	Cellulose Paper
560206-5110	6265-15	10 μm	—	Cellulose Paper
560206-5125	6265-16	25 μm	—	Cellulose Paper
560206-5140	6265-17	40 μm	—	Cellulose Paper

Mesh, Wire Cloth, Paper Dimensions = 2-5/8" O.D. x 7-1/4" lg. x 1-1/4" I.D.

MARVEL NO.	FLOW EZY NO.	DESCRIPTION		
561206-1120	F3-6265-03	74 μm	200	Mesh -epoxy & viton
561206-1115	F3-6265-07	100 μm	150	Mesh -epoxy & viton
561206-1110	F3-6265-02	150 μm	100	Mesh -epoxy & viton
561206-1108	F3-6265-08	190 μm	80	Mesh -epoxy & viton
561206-1106	F3-6265-01	230 μm	60	Mesh -epoxy & viton
561206-1105	F3-6265-09	280 μm	50	Mesh -epoxy & viton
561206-1104	F3-6265-10	370 μm	40	Mesh -epoxy & viton
561206-1103	F3-6265-11	540 μm	30	Mesh -epoxy & viton
561206-2210	F3-6265-05	10 μm	—	Wire Cloth -epoxy & viton
561206-2215	F3-6265-06	15 μm	—	Wire Cloth -epoxy & viton
561206-2225	F3-6265-04	25 μm	—	Wire Cloth -epoxy & viton
561206-2240	F3-6265-12	40 μm	—	Wire Cloth -epoxy & viton
561206-5101	F3-6265-13	1 μm	—	Cellulose Paper -epoxy & viton
561206-5105	F3-6265-14	5 μm	—	Cellulose Paper -epoxy & viton
561206-5110	F3-6265-15	10 μm	—	Cellulose Paper -epoxy & viton
561206-5125	F3-6265-16	25 μm	—	Cellulose Paper -epoxy & viton
561206-5140	F3-6265-17	40 μm	—	Cellulose Paper -epoxy & viton

PART NUMBER CROSS REFERENCE

Mesh, Wire Cloth, Paper Dimensions (closed bottom) = 4-1/2" O.D. x 7-1/4" lg. x 2-7/32" I.D.

MARVEL NO.	FLOW EZY NO.	DESCRIPTION		
576366-1120	6266-03	74 μm	200	Mesh
576366-1115	6266-07	100 μm	150	Mesh
576366-1110	6266-02	150 μm	100	Mesh
576366-1108	6266-08	190 μm	80	Mesh
576366-1106	6266-01	230 μm	60	Mesh
576366-1105	6266-09	280 μm	50	Mesh
576366-1104	6266-10	370 μm	40	Mesh
576366-1103	6266-11	540 μm	30	Mesh
576366-2210	6266-05	10 μm	—	Wire Cloth
576366-2215	6266-06	15 μm	—	Wire Cloth
576366-2225	6266-04	25 μm	—	Wire Cloth
576366-2240	6266-12	40 μm	—	Wire Cloth
576366-5101	6266-13	1 μm	—	Cellulose Paper
576366-5105	6266-14	5 μm	—	Cellulose Paper
576366-5110	6266-15	10 μm	—	Cellulose Paper
576366-5125	6266-16	25 μm	—	Cellulose Paper
576366-5140	6266-17	40 μm	—	Cellulose Paper

Mesh, Wire Cloth, Paper Dimensions (closed bottom) = 4-1/2" O.D. x 7-1/4" lg. x 2-7/32" I.D.

MARVEL NO.	FLOW EZY NO.	DESCRIPTION			
577366-1120	F3-6266-03	74 μm	200	Mesh	-epoxy & viton
577366-1115	F3-6266-07	100 μm	150	Mesh	-epoxy & viton
577366-1110	F3-6266-02	150 μm	100	Mesh	-epoxy & viton
577366-1108	F3-6266-08	190 μm	80	Mesh	-epoxy & viton
577366-1106	F3-6266-01	230 μm	60	Mesh	-epoxy & viton
577366-1105	F3-6266-09	280 μm	50	Mesh	-epoxy & viton
577366-1104	F3-6266-10	370 μm	40	Mesh	-epoxy & viton
577366-1103	F3-6266-11	540 μm	30	Mesh	-epoxy & viton
577366-2210	F3-6266-05	10 μm	—	Wire Cloth	-epoxy & viton
577366-2215	F3-6266-06	15 μm	—	Wire Cloth	-epoxy & viton
577366-2225	F3-6266-04	25 μm	—	Wire Cloth	-epoxy & viton
577366-2240	F3-6266-12	40 μm	—	Wire Cloth	-epoxy & viton
577366-5101	F3-6266-13	1 μm	—	Cellulose Paper	-epoxy & viton
577366-5105	F3-6266-14	5 μm	—	Cellulose Paper	-epoxy & viton
577366-5110	F3-6266-15	10 μm	—	Cellulose Paper	-epoxy & viton
577366-5125	F3-6266-16	25 μm	—	Cellulose Paper	-epoxy & viton
577366-5140	F3-6266-17	40 μm	—	Cellulose Paper	-epoxy & viton

PART NUMBER CROSS REFERENCE

Mesh, Wire Cloth, Paper Dimensions (closed bottom) = 4-1/2" O.D. x 9-3/4" lg. x 2-1/4" I.D.

MARVEL NO.	FLOW EZY NO.	DESCRIPTION		
578366-1120	6267-03	74 μm	200	Mesh
578366-1115	6267-07	100 μm	150	Mesh
578366-1110	6267-02	150 μm	100	Mesh
578366-1108	6267-08	190 μm	80	Mesh
578366-1106	6267-01	230 μm	60	Mesh
578366-1105	6267-09	280 μm	50	Mesh
578366-1104	6267-10	370 μm	40	Mesh
578366-1103	6267-11	540 μm	30	Mesh
578366-2210	6267-05	10 μm	—	Wire Cloth
578366-2215	6267-06	15 μm	—	Wire Cloth
578366-2225	6267-04	25 μm	—	Wire Cloth
578366-2240	6267-12	40 μm	—	Wire Cloth
578366-5101	6267-13	1 μm	—	Cellulose Paper
578366-5105	6267-14	5 μm	—	Cellulose Paper
578366-5110	6267-15	10 μm	—	Cellulose Paper
578366-5125	6267-16	25 μm	—	Cellulose Paper
578366-5140	6267-17	40 μm	—	Cellulose Paper

Mesh, Wire Cloth, Paper Dimensions (closed bottom) = 4-1/2" O.D. x 9-3/4" lg. x 2-1/4" I.D.

MARVEL NO.	FLOW EZY NO.	DESCRIPTION		
579366-1120	F3-6267-03	74 μm	200	Mesh -epoxy & viton
579366-1115	F3-6267-07	100 μm	150	Mesh -epoxy & viton
579366-1110	F3-6267-02	150 μm	100	Mesh -epoxy & viton
579366-1108	F3-6267-08	190 μm	80	Mesh -epoxy & viton
579366-1106	F3-6267-01	230 μm	60	Mesh -epoxy & viton
579366-1105	F3-6267-09	280 μm	50	Mesh -epoxy & viton
579366-1104	F3-6267-10	370 μm	40	Mesh -epoxy & viton
579366-1103	F3-6267-11	540 μm	30	Mesh -epoxy & viton
579366-2210	F3-6267-05	10 μm	—	Wire Cloth -epoxy & viton
579366-2215	F3-6267-06	15 μm	—	Wire Cloth -epoxy & viton
579366-2225	F3-6267-04	25 μm	—	Wire Cloth -epoxy & viton
579366-2240	F3-6267-12	40 μm	—	Wire Cloth -epoxy & viton
579366-5101	F3-6267-13	1 μm	—	Cellulose Paper -epoxy & viton
579366-5105	F3-6267-14	5 μm	—	Cellulose Paper -epoxy & viton
579366-5110	F3-6267-15	10 μm	—	Cellulose Paper -epoxy & viton
579366-5125	F3-6267-16	25 μm	—	Cellulose Paper -epoxy & viton
579366-5140	F3-6267-17	40 μm	—	Cellulose Paper -epoxy & viton

PART NUMBER CROSS REFERENCE

Mesh, Wire Cloth, Paper Dimensions = 2-5/8" O.D. x 5" lg. x 1-1/4" I.D.

MARVEL NO.	FLOW EZY NO.	DESCRIPTION		
629206-1120	6264-03	74 μm	200	Mesh
629206-1115	6264-07	100 μm	150	Mesh
629206-1110	6264-02	150 μm	100	Mesh
629206-1108	6264-08	190 μm	80	Mesh
629206-1106	6264-01	230 μm	60	Mesh
629206-1105	6264-09	280 μm	50	Mesh
629206-1104	6264-10	370 μm	40	Mesh
629206-1103	6264-11	540 μm	30	Mesh
629206-2210	6264-05	10 μm	—	Wire Cloth
629206-2215	6264-06	15 μm	—	Wire Cloth
629206-2225	6264-04	25 μm	—	Wire Cloth
629206-2240	6264-12	40 μm	—	Wire Cloth
629206-5101	6264-13	1 μm	—	Cellulose Paper
629206-5105	6264-14	5 μm	—	Cellulose Paper
629206-5110	6264-15	10 μm	—	Cellulose Paper
629206-5125	6264-16	25 μm	—	Cellulose Paper
629206-5140	6264-17	40 μm	—	Cellulose Paper

Mesh, Wire Cloth, Paper Dimensions = 2-5/8" O.D. x 5" lg. x 1-1/4" I.D.

MARVEL NO.	FLOW EZY NO.	DESCRIPTION		
630206-1120	F3-6264-03	74 μm	200	Mesh -epoxy & viton
630206-1115F3-6264-07	100	μm 150	Mesh	-epoxy & viton
630206-1110F3-6264-02	150	μm 100	Mesh	-epoxy & viton
630206-1108	F3-6264-08	190 μm	80	Mesh -epoxy & viton
630206-1106	F3-6264-01	230 μm	60	Mesh -epoxy & viton
630206-1105	F3-6264-09	280 μm	50	Mesh -epoxy & viton
630206-1104	F3-6264-10	370 μm	40	Mesh -epoxy & viton
630206-1103	F3-6264-11	540 μm	30	Mesh -epoxy & viton
630206-2210	F3-6264-05	10 μm	—	Wire Cloth -epoxy & viton
630206-2215	F3-6264-06	15 μm	—	Wire Cloth -epoxy & viton
630206-2225	F3-6264-04	25 μm	—	Wire Cloth -epoxy & viton
630206-2240	F3-6264-12	40 μm	—	Wire Cloth -epoxy & viton
630206-5101	F3-6264-13	1 μm	—	Cellulose Paper -epoxy & viton
630206-5105	F3-6264-14	5 μm	—	Cellulose Paper -epoxy & viton
630206-5110	F3-6264-15	10 μm	—	Cellulose Paper -epoxy & viton
630206-5125	F3-6264-16	25 μm	—	Cellulose Paper -epoxy & viton
630206-5140	F3-6264-17	40 μm	—	Cellulose Paper -epoxy & viton

PART NUMBER CROSS REFERENCE

Mesh, Wire Cloth, Paper Dimensions = 3" O.D. x 7-1/2" lg. x 1-5/8" I.D.

MARVEL NO.	FLOW EZY NO.	DESCRIPTION		
664266-1120	6109-03	74 μm	200	Mesh
664266-1115	6109-07	100 μm	150	Mesh
664266-1110	6109-02	150 μm	100	Mesh
664266-1108	6109-08	190 μm	80	Mesh
664266-1106	6109-01	230 μm	60	Mesh
664266-1105	6109-09	280 μm	50	Mesh
664266-1104	6109-10	370 μm	40	Mesh
664266-1103	6109-11	540 μm	30	Mesh
664266-2210	6109-05	10 μm	—	Wire Cloth
664266-2215	6109-06	15 μm	—	Wire Cloth
664266-2225	6109-04	25 μm	—	Wire Cloth
664266-2240	6109-12	40 μm	—	Wire Cloth
664266-5101	6109-13	1 μm	—	Cellulose Paper
664266-5105	6109-14	5 μm	—	Cellulose Paper
664266-5110	6109-15	10 μm	—	Cellulose Paper
664266-5125	6109-16	25 μm	—	Cellulose Paper
664266-5140	6109-17	40 μm	—	Cellulose Paper

Mesh, Wire Cloth, Paper Dimensions = 3" O.D. x 7-1/2" lg. x 1-5/8" I.D.

MARVEL NO.	FLOW EZY NO.	DESCRIPTION		
665266-1120	F3-6109-03	74 μm	200	Mesh -epoxy & viton
665266-1115	F3-6109-07	100 μm	150	Mesh -epoxy & viton
665266-1110	F3-6109-02	150 μm	100	Mesh -epoxy & viton
665266-1108	F3-6109-08	190 μm	80	Mesh -epoxy & viton
665266-1106	F3-6109-01	230 μm	60	Mesh -epoxy & viton
665266-1105	F3-6109-09	280 μm	50	Mesh -epoxy & viton
665266-1104	F3-6109-10	370 μm	40	Mesh -epoxy & viton
665266-1103	F3-6109-11	540 μm	30	Mesh -epoxy & viton
665266-2210	F3-6109-05	10 μm	—	Wire Cloth -epoxy & viton
665266-2215	F3-6109-06	15 μm	—	Wire Cloth -epoxy & viton
665266-2225	F3-6109-04	25 μm	—	Wire Cloth -epoxy & viton
665266-2240	F3-6109-12	40 μm	—	Wire Cloth -epoxy & viton
665266-5101	F3-6109-13	1 μm	—	Cellulose Paper -epoxy & viton
665266-5105	F3-6109-14	5 μm	—	Cellulose Paper -epoxy & viton
665266-5110	F3-6109-15	10 μm	—	Cellulose Paper -epoxy & viton
665266-5125	F3-6109-16	25 μm	—	Cellulose Paper -epoxy & viton
665266-5140	F3-6109-17	40 μm	—	Cellulose Paper -epoxy & viton

PART NUMBER CROSS REFERENCE

Mesh, Wire Cloth, Paper Dimensions = 3-3/8" O.D. x 7-1/2" lg. x 1-7/8" I.D.

MARVEL NO.	FLOW EZY NO.	DESCRIPTION		
668306-1120	6110-03	74 μ m	200	Mesh
668306-1115	6110-07	100 μ m	150	Mesh
668306-1110	6110-02	150 μ m	100	Mesh
668306-1108	6110-08	190 μ m	80	Mesh
668306-1106	6110-01	230 μ m	60	Mesh
668306-1105	6110-09	280 μ m	50	Mesh
668306-1104	6110-10	370 μ m	40	Mesh
668306-1103	6110-11	540 μ m	30	Mesh
668306-2210	6110-05	10 μ m	—	Wire Cloth
668306-2215	6110-06	15 μ m	—	Wire Cloth
668306-2225	6110-04	25 μ m	—	Wire Cloth
668306-2240	6110-12	40 μ m	—	Wire Cloth
668306-5101	6110-13	1 μ m	—	Cellulose Paper
668306-5105	6110-14	5 μ m	—	Cellulose Paper
668306-5110	6110-15	10 μ m	—	Cellulose Paper
668306-5125	6110-16	25 μ m	—	Cellulose Paper
668306-5140	6110-17	40 μ m	—	Cellulose Paper

Mesh, Wire Cloth, Paper Dimensions = 3-3/8" O.D. x 7-1/2" lg. x 1-7/8" I.D.

MARVEL NO.	FLOW EZY NO.	DESCRIPTION		
669306-1120	F3-6110-03	74 μ m	200	Mesh -epoxy & viton
669306-1115	F3-6110-07	100 μ m	150	Mesh -epoxy & viton
669306-1110	F3-6110-02	150 μ m	100	Mesh -epoxy & viton
669306-1108	F3-6110-08	190 μ m	80	Mesh -epoxy & viton
669306-1106	F3-6110-01	230 μ m	60	Mesh -epoxy & viton
669306-1105	F3-6110-09	280 μ m	50	Mesh -epoxy & viton
669306-1104	F3-6110-10	370 μ m	40	Mesh - epoxy & viton
669306-1103	F3-6110-11540	μ m 30	Mesh	-epoxy & viton
669306-2210	F3-6110-05	10 μ m	—	Wire Cloth -epoxy & viton
669306-2215	F3-6110-06	15 μ m	—	Wire Cloth -epoxy & viton
669306-2225	F3-6110-04	25 μ m	—	Wire Cloth -epoxy & viton
669306-2240	F3-6110-12	40 μ m	—	Wire Cloth -epoxy & viton
669306-5101	F3-6110-13	1 μ m	—	Cellulose Paper -epoxy & viton
669306-5105	F3-6110-14	5 μ m	—	Cellulose Paper -epoxy & viton
669306-5110	F3-6110-15	10 μ m	—	Cellulose Paper -epoxy & viton
669306-5125	F3-6110-16	25 μ m	—	Cellulose Paper -epoxy & viton
669306-5140	F3-6110-17	40 μ m	—	Cellulose Paper -epoxy & viton

PART NUMBER CROSS REFERENCE

Mesh, Wire Cloth, Paper Dimensions = 4-1/2" O.D. x 7-1/2" lg. x 2-1/4" I.D.

MARVEL NO.	FLOW EZY NO.	DESCRIPTION		
676366-1120	6111-03	74 μm	200	Mesh
676366-1115	6111-07	100 μm	150	Mesh
676366-1110	6111-02	150 μm	100	Mesh
676366-1108	6111-08	190 μm	80	Mesh
676366-1106	6111-01	230 μm	60	Mesh
676366-1105	6111-09	280 μm	50	Mesh
676366-1104	6111-10	370 μm	40	Mesh
676366-1103	6111-11	540 μm	30	Mesh
676366-2210	6111-05	10 μm	—	Wire Cloth
676366-2215	6111-06	15 μm	—	Wire Cloth
676366-2225	6111-04	25 μm	—	Wire Cloth
676366-2240	6111-12	40 μm	—	Wire Cloth
676366-5101	6111-13	1 μm	—	Cellulose Paper
676366-5105	6111-14	5 μm	—	Cellulose Paper
676366-5110	6111-15	10 μm	—	Cellulose Paper
676366-5125	6111-16	25 μm	—	Cellulose Paper
676366-5140	6111-17	40 μm	—	Cellulose Paper

Mesh, Wire Cloth, Paper Dimensions = 4-1/4" O.D. x 7-1/2" lg. x 2-1/4" I.D.

MARVEL NO.	FLOW EZY NO.	DESCRIPTION		
677366-1120	F3-6111-0374	μm 200 Mesh		-epoxy & viton
677366-1115	F3-6111-07100	μm 150 Mesh		-epoxy & viton
677366-1110	F3-6111-02150	μm 100 Mesh		-epoxy & viton
677366-1108	F3-6111-08190	μm 80 Mesh		-epoxy & viton
677366-1106	F3-6111-01230	μm 60 Mesh		-epoxy & viton
677366-1105	F3-6111-09280	μm 50 Mesh		-epoxy & viton
677366-1104	F3-6111-10370	μm 40 Mesh		-epoxy & viton
677366-1103	F3-6111-11540	μm 30 Mesh		-epoxy & viton
677366-2210	F3-6111-0510	μm —Wire Cloth		-epoxy & viton
677366-2215	F3-6111-0615	μm —Wire Cloth		-epoxy & viton
677366-2225	F3-6111-0425	μm —Wire Cloth		-epoxy & viton
677366-2240	F3-6111-1240	μm —Wire Cloth		-epoxy & viton
677366-5101	F3-6111-131	μm —Cellulose Paper		-epoxy & viton
677366-5105	F3-6111-145	μm —Cellulose Paper		-epoxy & viton
677366-5110	F3-6111-1510	μm —Cellulose Paper		-epoxy & viton
677366-5125	F3-6111-1625	μm —Cellulose Paper		-epoxy & viton
677366-5140	F3-6111-1740	μm —Cellulose Paper		-epoxy & viton

PART NUMBER CROSS REFERENCE

Mesh, Wire Cloth, Paper Dimensions = 4-1/2" O.D. x 7-1/2" lg. x 2-3/8" I.D.

MARVEL NO.	FLOW EZY NO.	DESCRIPTION		
676386-1120	6235-03	74 μ m	200	Mesh
676386-1115	6235-07	100 μ m	150	Mesh
676386-1110	6235-02	150 μ m	100	Mesh
676386-1108	6235-08	190 μ m	80	Mesh
676386-1106	6235-01	230 μ m	60	Mesh
676386-1105	6235-09	280 μ m	50	Mesh
676386-1104	6235-10	370 μ m	40	Mesh
676386-1103	6235-11	540 μ m	30	Mesh
676386-2210	6235-05	10 μ m	—	Wire Cloth
676386-2215	6235-06	15 μ m	—	Wire Cloth
676386-2225	6235-04	25 μ m	—	Wire Cloth
676386-2240	6235-12	40 μ m	—	Wire Cloth
676386-5101	6235-13	1 μ m	—	Cellulose Paper
676386-5105	6235-14	5 μ m	—	Cellulose Paper
676386-5110	6235-15	10 μ m	—	Cellulose Paper
676386-5125	6235-16	25 μ m	—	Cellulose Paper
676386-5140	6235-17	40 μ m	—	Cellulose Paper

Mesh, Wire Cloth, Paper Dimensions = 4-1/2" O.D. x 7-1/2" lg. x 2-3/8" I.D.

MARVEL NO.	FLOW EZY NO.	DESCRIPTION			
677386-1120	F3-6235-03	74 μ m	200	Mesh	-epoxy & viton
677386-1115	F3-6235-07	100 μ m	150	Mesh	-epoxy & viton
677386-1110	F3-6235-02	150 μ m	100	Mesh	-epoxy & viton
677386-1108	F3-6235-08	190 μ m	80	Mesh	-epoxy & viton
677386-1106	F3-6235-01	230 μ m	60	Mesh	-epoxy & viton
677386-1105	F3-6235-09	280 μ m	50	Mesh	-epoxy & viton
677386-1104	F3-6235-10	370 μ m	40	Mesh	-epoxy & viton
677386-1103	F3-6235-11	540 μ m	30	Mesh	-epoxy & viton
677386-2210	F3-6235-05	10 μ m	—	Wire Cloth	-epoxy & viton
677386-2215	F3-6235-06	15 μ m	—	Wire Cloth	-epoxy & viton
677386-2225	F3-6235-04	25 μ m	—	Wire Cloth	-epoxy & viton
677386-2240	F3-6235-12	40 μ m	—	Wire Cloth	-epoxy & viton
677386-5101	F3-6235-13	1 μ m	—	Cellulose Paper	-epoxy & viton
677386-5105	F3-6235-14	5 μ m	—	Cellulose Paper	-epoxy & viton
677386-5110	F3-6235-15	10 μ m	—	Cellulose Paper	-epoxy & viton
677386-5125	F3-6235-16	25 μ m	—	Cellulose Paper	-epoxy & viton
677386-5140	F3-6235-17	40 μ m	—	Cellulose Paper	-epoxy & viton

PART NUMBER CROSS REFERENCE

Mesh, Wire Cloth, Paper Dimensions = 5-1/2" O.D. x 9-7/8" lg. x 2-7/8" I.D.

MARVEL NO.	FLOW EZY NO.	DESCRIPTION		
682466-1120	6236-03	74 μm	200	Mesh
682466-1115	6236-07	100 μm	150	Mesh
682466-1110	6236-02	150 μm	100	Mesh
682466-1108	6236-08	190 μm	80	Mesh
682466-1106	6236-01	230 μm	60	Mesh
682466-1105	6236-09	280 μm	50	Mesh
682466-1104	6236-10	370 μm	40	Mesh
682466-1103	6236-11	540 μm	30	Mesh
682466-2210	6236-05	10 μm	—	Wire Cloth
682466-2215	6236-06	15 μm	—	Wire Cloth
682466-2225	6236-04	25 μm	—	Wire Cloth
682466-2240	6236-12	40 μm	—	Wire Cloth
682466-5101	6236-13	1 μm	—	Cellulose Paper
682466-5105	6236-14	5 μm	—	Cellulose Paper
682466-5110	6236-15	10 μm	—	Cellulose Paper
682466-5125	6236-16	25 μm	—	Cellulose Paper
682466-5140	6236-17	40 μm	—	Cellulose Paper

Mesh, Wire Cloth, Paper Dimensions = 5-1/2" O.D. x 9-7/8" lg. x 2-7/8" I.D.

MARVEL NO.	FLOW EZY NO.	DESCRIPTION		
683466-1120	F3-6236-03	74 μm	200	Mesh -epoxy & viton
683466-1115	F3-6236-07	100 μm	150	Mesh -epoxy & viton
683466-1110	F3-6236-02	150 μm	100	Mesh -epoxy & viton
683466-1108	F3-6236-08	190 μm	80	Mesh -epoxy & viton
683466-1106	F3-6236-01	230 μm	60	Mesh -epoxy & viton
683466-1105	F3-6236-09	280 μm	50	Mesh -epoxy & viton
683466-1104	F3-6236-10	370 μm	40	Mesh -epoxy & viton
683466-1103	F3-6236-11	540 μm	30	Mesh -epoxy & viton
683466-2210	F3-6236-05	10 μm	—	Wire Cloth -epoxy & viton
683466-2215	F3-6236-06	15 μm	—	Wire Cloth -epoxy & viton
683466-2225	F3-6236-04	25 μm	—	Wire Cloth -epoxy & viton
683466-2240	F3-6236-12	40 μm	—	Wire Cloth -epoxy & viton
683466-5101	F3-6236-13	1 μm	—	Cellulose Paper -epoxy & viton
683466-5105	F3-6236-14	5 μm	—	Cellulose Paper -epoxy & viton
683466-5110	F3-6236-15	10 μm	—	Cellulose Paper -epoxy & viton
683466-5125	F3-6236-16	25 μm	—	Cellulose Paper -epoxy & viton
683466-5140	F3-6236-17	40 μm	—	Cellulose Paper - epoxy & viton

PART NUMBER CROSS REFERENCE

Mesh, Wire Cloth, Paper Dimensions = 6-1/2" O.D. x 10" lg. x 3-1/2" I.D.

MARVEL NO.	FLOW EZY NO.	DESCRIPTION		
686566-1120	6268-03	74 μ m	200	Mesh
686566-1115	6268-07	100 μ m	150	Mesh
686566-1110	6268-02	150 μ m	100	Mesh
686566-1108	6268-08	190 μ m	80	Mesh
686566-1106	6268-01	230 μ m	60	Mesh
686566-1105	6268-09	280 μ m	50	Mesh
686566-1104	6268-10	370 μ m	40	Mesh
686566-1103	6268-11	540 μ m	30	Mesh
686566-2210	6268-05	10 μ m	—	Wire Cloth
686566-2215	6268-06	15 μ m	—	Wire Cloth
686566-2225	6268-04	25 μ m	—	Wire Cloth
686566-2240	6268-12	40 μ m	—	Wire Cloth
686566-5101	6268-13	1 μ m	—	Cellulose Paper
686566-5105	6268-14	5 μ m	—	Cellulose Paper
686566-5110	6268-15	10 μ m	—	Cellulose Paper
686566-5125	6268-16	25 μ m	—	Cellulose Paper
686566-5140	6268-17	40 μ m	—	Cellulose Paper

Mesh, Wire Cloth, Paper Dimensions = 6-1/2" O.D. x 10" lg. x 3-1/2" I.D.

MARVEL NO.	FLOW EZY NO.	DESCRIPTION		
687566-1120	F3-6268-03	74 μ m	200	Mesh -epoxy & viton
687566-1115	F3-6268-07	100 μ m	150	Mesh -epoxy & viton
687566-1110	F3-6268-02	150 μ m	100	Mesh -epoxy & viton
687566-1108	F3-6268-08	190 μ m	80	Mesh -epoxy & viton
687566-1106	F3-6268-01	230 μ m	60	Mesh -epoxy & viton
687566-1105	F3-6268-09	280 μ m	50	Mesh -epoxy & viton
687566-1104	F3-6268-10	370 μ m	40	Mesh -epoxy & viton
687566-1103	F3-6268-11	540 μ m	30	Mesh -epoxy & viton
687566-2210	F3-6268-05	10 μ m	—	Wire Cloth -epoxy & viton
687566-2215	F3-6268-06	15 μ m	—	Wire Cloth -epoxy & viton
687566-2225	F3-6268-04	25 μ m	—	Wire Cloth -epoxy & viton
687566-2240	F3-6268-12	40 μ m	—	Wire Cloth -epoxy & viton
687566-5101	F3-6268-13	1 μ m	—	Cellulose Paper -epoxy & viton
687566-5105	F3-6268-14	5 μ m	—	Cellulose Paper -epoxy & viton
687566-5110	F3-6268-15	10 μ m	—	Cellulose Paper -epoxy & viton
687566-5125	F3-6268-16	25 μ m	—	Cellulose Paper -epoxy & viton
687566-5140	F3-6268-17	40 μ m	—	Cellulose Paper -epoxy & viton

OTHER FLOW EZY CATALOGS

CALL 800-237-1165 FOR ANY OF OUR OTHER CATALOGS

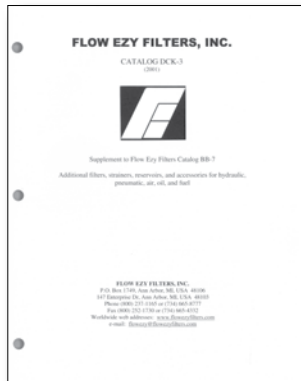

**MORE
FILTERS,
STRAINERS,
ACCESSORIES**

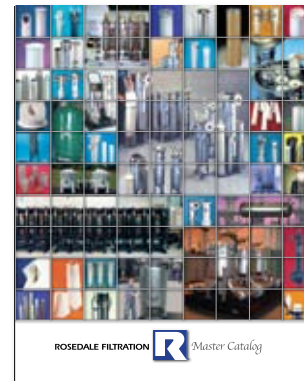

**FILTER
HOUSINGS,
MEDIA,
ACCESSORIES**

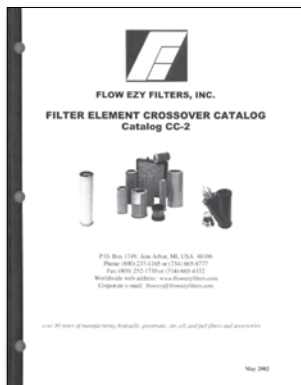

**FILTER
ELEMENT
CROSSOVER
CATALOG**

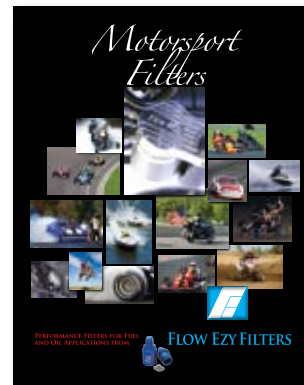

**MOTORSPORT
FILTER
CATALOG**

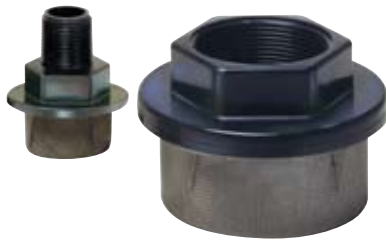





FLOW EZY FILTERS, INC.

P.O. Box 1749, Ann Arbor, MI 48106
Tel 734-665-8777 or 800-237-1165
Fax 734-665-4332 or 800-252-1730
flowezy@flowezyfilters.com
www.flowezyfilters.com